

METRASEAL

Pipe Wall Penetration Seals



MetraSeal

**Off Center
Seal**

**Modular Riser
Guide**

Metraflex
for pipes in motion

2323 W. HUBBARD ST. • CHICAGO, IL 60612 • 312-738-3800 • FAX 312-738-0415 • www.metraflex.com

METRASEAL: A WATER TIGHT MECHANICAL SEAL

- Installs around any pipe or conduit
- Hydrostatically seals the penetration up to 40 psi*
- Waterproof, no drying or curing time
- Heatproof, silicone option good to 400°F
- Misalignment proof, off-center seals allow eccentric installation
- Foolproof, slide it in the hole and tighten it up

The Metraflex MetraSeal quickly fills the space around any round pipe, including concrete, steel, plastic, cast iron, copper, telecommunications cable and electric conduit, with a snug, permanent seal.

Engineered as a permanent seal, the MetraSeal can withstand up to 40 psig in well installed conditions. With over 20 years sealing expertise, Metraflex's design has enabled MetraSeals to survive in service conditions for 20+ years! The MetraSeal seals out groundwater in subgrade exterior walls, and absorbs noise and vibration in mechanical rooms.

MetraSeals can be installed in all field conditions. Operating temperatures range from -40 to 400°F. MetraSeal's unique mechanical type link construction allows installation without any moisture or drying requirements, including fully submersed locations.

*Max rating applies to well installed conditions consisting of a round, smooth penetration free from debris or weld slag, a centered pipe in a manufactured surface condition, and a completely tightened and secured MetraSeal belt.

Install a MetraSeal wherever pipe penetrates the floor, ceiling or wall.

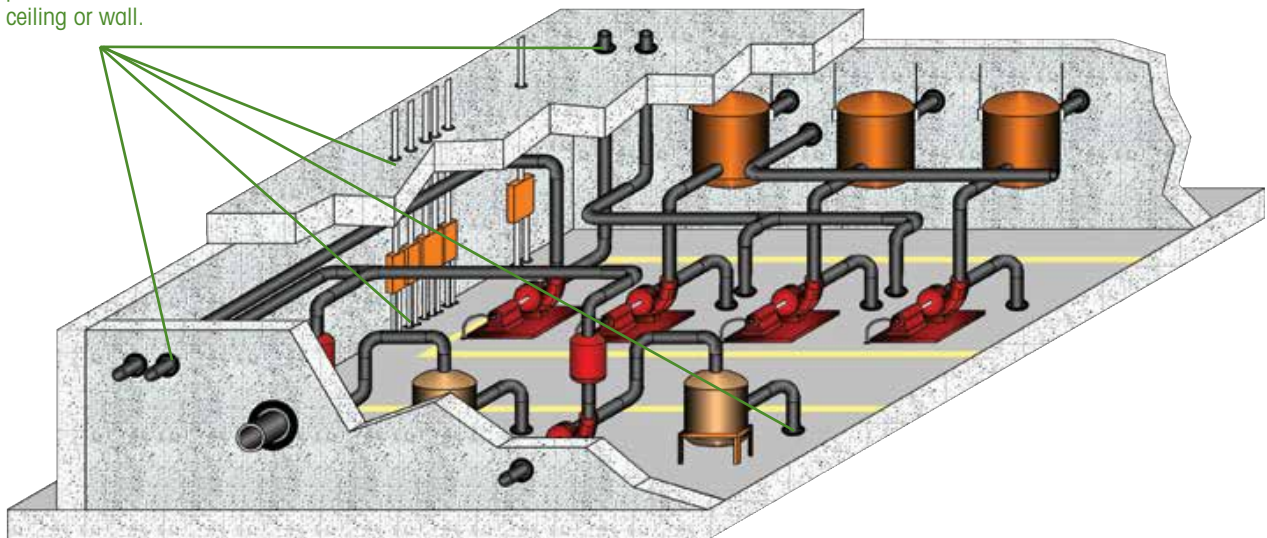

The MetraSeal effectively "seals off" the mechanical room from the rest of the system. Noise amplitude reductions up to 52%.

KEEP NOISE, VIBRATION OR FLOOD CONFINED TO THE MECHANICAL ROOM

INSTALLATION INSTRUCTIONS

The MetraSeal forms a water-tight mechanical seal between the pipe and the hole through which it passes.

Easy as One, Two, Three

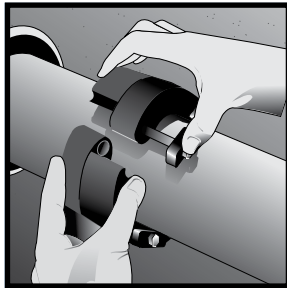

- 1. Wrap the belt around the pipe. Then connect the first and last links.**

Asegure el cinturón alrededor del tubo. Conecte el primero y el último eslabón.

Enveloppez la ceinture autour du tuyau. Ensuite reliez les premières et dernières tiges d'assemblage.

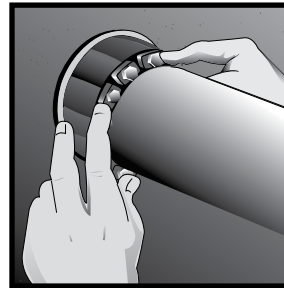

- 2. Slide the assembly into the space between the pipe and wall.**

Deslice el ensamble en el espacio entre el tubo y la pared.

Glissez l'assemblage dans l'espace entre le tuyau et le mur.

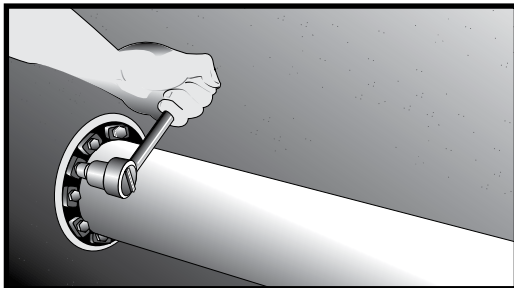

- 3. Gradually and sequentially tighten the bolts. Tighten each bolt 2-3 turns making multiple passes completely around the pipe until the seal is secure. You should see the rubber bulge between the pressure plates. Do not cross tighten. The MetraSeal links expand to create a gas and water tight seal.**

Apriete secuencialmente y gradualmente los cerrojos. Apriete cada cerrojo de 2 a 3 vueltas. Apriete consecutivamente alrededor del tubo hasta hacerlo de 4 a 7 repeticiones. Usted debe ver el bulto de goma entre las placas de presión. No cruce al apretar los cerrojos! Los eslabones se expanden creando un sello apretado de gas y agua.

Graduellement et d'une façon séquentielle serrez les boulons. Serrez chaque boulon 2 à 3 tours en tournant complètement autour du tuyau 4 à 7 fois. Vous devriez voir le renflement en caoutchouc entre les plaques de pression. Ne serrez pas les boulons de manière croisée. Les tiges d'assemblage MetraSeal se dilatent pour créer une cloison étanche à l'eau et au gaz.

How it works

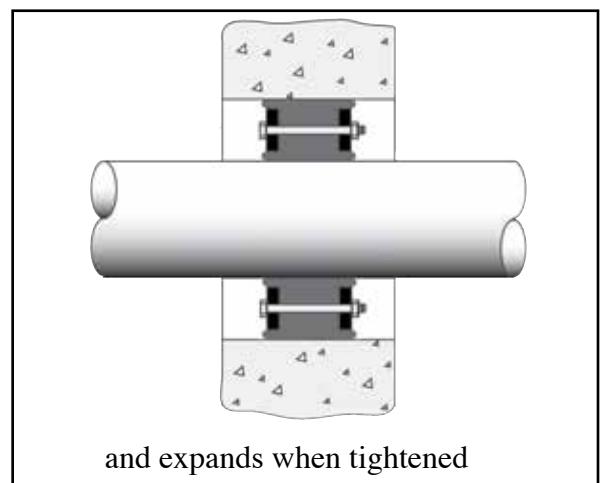
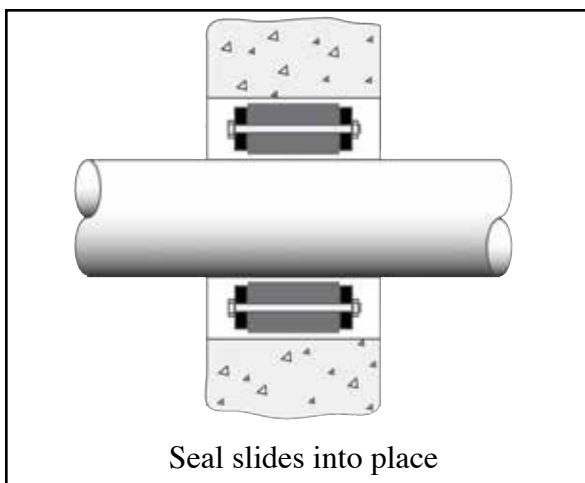

METRASEAL SELECTION FLOW CHART

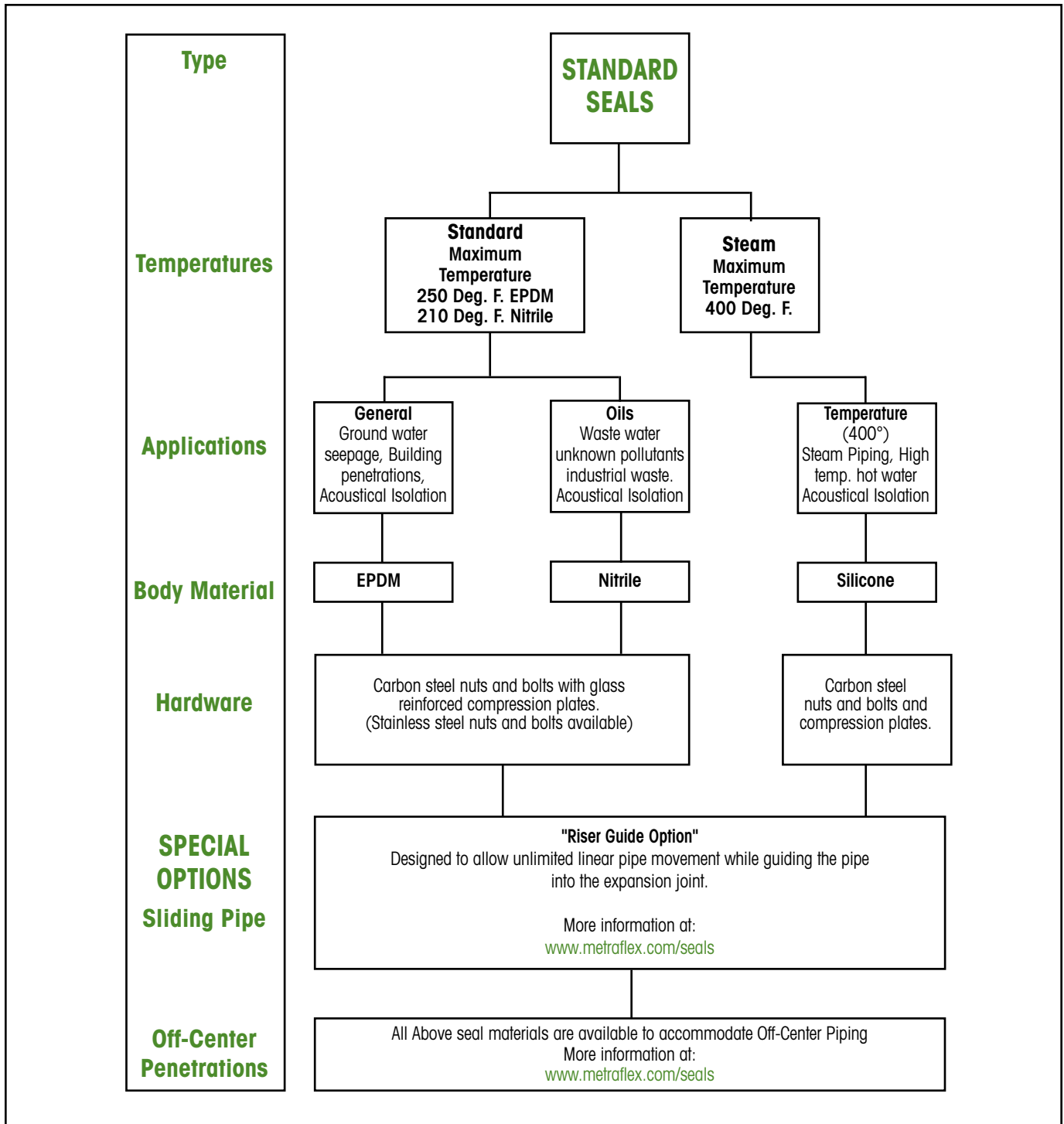

METRASEAL SELECTION GUIDE

For most applications, the appropriate MetraSeal can be selected from the charts on pages 6, 7, 8 and 9. If your pipe and wall opening dimensions do not appear on these charts, use the methods on page 10.

1. Find the chart that applies to your pipe material. Next, locate your pipe size.
2. Determine your wall opening. Select either the standard weight steel or PVC wall sleeve that was used or the diameter of the core bit drilled hole.
3. Find your "Nominal Pipe Size". Then read across to the sizing section for wall sleeves or core bit drilled holes. The first column identifies either the nominal wall sleeve size, or the hole I.D. The appropriate MetraSeal model and number of links required is shown to the right.
4. Select the MetraSeal type from the table below.
5. To order, designate the number of links required, followed by the combination of the MetraSeal model and type. For example:

A 6" schedule 40 pipe in a 10" wall sleeve would be ordered as a 1 0 M S 4 7 5 E.

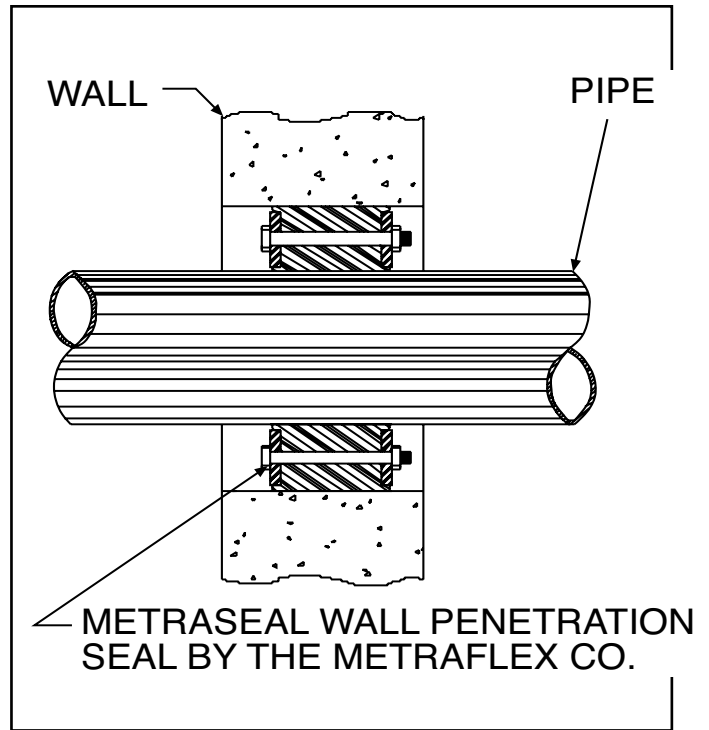

TYPE	SEAL MATERIAL	PRESSURE PLATES	BOLTS & NUTS	TEMPERATURE RANGE (°F)	APPLICATIONS*
E	EPDM Black	GLASS REINFORCED PLASTIC	STEEL zinc dichromate	-40 to +250	Suitable for most applications in water, both above ground and direct burial. Provides electrical insulation where cathodic protection is required.
ES	EPDM Black	GLASS REINFORCED PLASTIC	STAINLESS STEEL (18-8)	-40 to +250	Suitable for environments where the corrosion resistance of stainless steel hardware is required.
P	NITRILE	GLASS REINFORCED PLASTIC	STEEL zinc dichromate	-40 to +210	Resistant to most hydrocarbons, oil, gas, jet fuel, and many solvents.
PS	NITRILE	GLASS REINFORCED PLASTIC	STAINLESS STEEL (18-8)	-40 to +210	Same as above but with corrosion resistance of stainless steel hardware.
HT	Silicone	STEEL ZINC DICHROMATE	STEEL zinc dichromate	-40 to +400	High temperature applications.

*For more details and complete chemical compatibility contact factory.

METRASeal SELECTION CHARTS

Sizing for Steel PVC and CPVC pipe

Nominal Pipe Size	Actual Pipe O.D.	Standard Weight Steel or PVC Pipe Sleeve*				Cast or core bit drilled hole*		
		Sleeve Nominal Pipe Size	Sleeve Actual I.D.	MetraSeal Model no.	Number of links required	Hole I.D.	MetraSeal Model no.	Number of links required
1/2"	0.840"	2"	2.067"	MS-200	4	2.0"	MS-200	4
3/4"	1.050"	2-1/2"	2.469"	MS-275	6	2.5"	MS-275	6
1"	1.315"	2-1/2"	2.469"	MS-200	5	3.0"	MS-315	4
1-1/4"	1.660"	3"	3.068"	MS-275	8	3.0"	MS-275	8
1-1/2"	1.900"	3"	3.068"	MS-200	7	3.5"	MS-300	5
2"	2.375"	3-1/2"	3.548"	MS-200	8	4.0"	MS-300	6
2-1/2"	2.875"	4"	4.026"	MS-200	9	4.0"	MS-200	9
3"	3.500"	5"	5.047"	MS-300	8	5.0"	MS-300	8
3-1/2"	4.000"	6"	6.065"	MS-315	10	6.0"	MS-315	10
4"	4.500"	6"	6.065"	MS-300	10	6.0"	MS-300	10
5"	5.563"	8"	7.981"	MS-340	13	8.0"	MS-340	13
6"	6.625"	10"	10.02"	MS-475	10	10.0"	MS-475	10
8"	8.625"	12"	12.00"	MS-475	12	12.0"	MS-475	12
10"	10.750"	14"	13.25"	MS-425	10	14.0"	MS-475	14
12"	12.750"	16"	15.25"	MS-425	12	16.0"	MS-475	17
14"	14.000"	18"	17.25"	MS-475	18	18.0"	MS-575	16
16"	16.000"	20"	19.25"	MS-475	21	20.0"	MS-575	18
18"	18.000"	22"	21.25"	MS-475	23	22.0"	MS-575	20
20"	20.000"	24"	23.25"	MS-475	25	24.0"	MS-575	22
22"	22.000"	26"	25.25"	MS-475	28	26.0"	MS-575	24
24"	24.000"	28"	27.25"	MS-475	30	28.0"	MS-575	26
26"	26.000"	30"	29.25"	MS-475	33	30.0"	MS-575	28
28"	28.000"	32"	31.25"	MS-475	35	32.0"	MS-575	30
30"	30.000"	34"	33.25"	MS-475	37	34.0"	MS-575	32
32"	32.000"	36"	35.25"	MS-475	40	36.0"	MS-575	34
34"	34.000"	40"	39.25"	MS-500	29	38.0"	MS-575	36
36"	36.000"	42"	41.25"	MS-500	31	40.0"	MS-575	38
42"	42.000"	48"	47.25"	MS-500	36	46.0"	MS-575	44
48"	48.000"	54"	53.25"	MS-500	41	52.0"	MS-575	50

*Minimum recommended sleeve length or wall thickness is 4" for MetraSeal model 325 and smaller and 6" for models 400 and larger.

If you do not see your pipe/hole combination, see page 10 or the web seal calculator at <http://www.metroflex.com/metraseal>

METRASEAL SELECTION CHARTS

Copper Tubing

Nominal Pipe Size	Actual Pipe O.D.	Standard Weight Steel or PVC Pipe Sleeve*				Cast or core bit drilled hole*		
		Sleeve Nominal Pipe Size	Sleeve Actual I.D.	MetraSeal Model no.	Number of links required	Hole I.D.	MetraSeal Model no.	Number of links required
1/2"	.625"	2"	2.067"	MS-275	4	2.0"	MS-275	4
3/4"	.875"	2"	2.067"	MS-200	4	2.0"	MS-200	4
1"	1.125"	2-1/2"	2.469"	MS-275	6	3.0"	MS-315	4
1-1/4"	1.375"	2-1/2"	2.469"	MS-200	5	3.0"	MS-300	4
1-1/2"	1.625"	3"	3.068"	MS-275	8	3.0"	MS-275	8
2"	2.125"	3-1/2"	3.548"	MS-300	5	3.5"	MS-275	9
2-1/2"	2.625"	4"	4.026"	MS-275	11	4.0"	MS-275	11
3"	3.125"	5"	5.047"	MS-315	8	5.0"	MS-315	8
4"	4.125"	6"	6.065"	MS-315	10	6.0"	MS-315	10
6"	6.125"	8"	7.981"	MS-315	15	8.0"	MS-315	15
8"	8.125"	10"	10.02"	MS-325	9	12.0"	MS-575	10
10"	10.125"	14"	13.25"	MS-410	14	14.0"	MS-575	12
12"	12.125"	16"	15.25"	MS-410	16	16.0"	MS-575	14

Electrical Metallic Tubing (EMT)

Nominal Conduit Size	Actual O.D. Inches	Standard Weight Steel or PVC Pipe Sleeve*				Cast or core bit drilled hole*		
		Sleeve Nominal Pipe Size	Sleeve Actual I.D.	MetraSeal Model no.	Number of links required	Hole I.D.	MetraSeal Model no.	Number of links required
1/2"	.706"	2"	2.067"	MS-275	4	2.0"	MS-275	4
3/4"	.922"	2"	2.067"	MS-200	4	2.0"	MS-200	4
1"	1.163"	2-1/2"	2.469"	MS-275	6	3.0"	MS-315	4
1-1/4"	1.510"	3"	3.068"	MS-275	7	3.0"	MS-275	4
1-1/2"	1.740"	3-1/2"	3.548"	MS-315	5	3.5"	MS-315	5
2"	2.197"	3-1/2"	3.548"	MS-275	10	4.0"	MS-315	6
2-1/2"	2.875"	4"	4.026"	MS-200	9	4.0"	MS-200	9
3"	3.500"	5"	5.047"	MS-300	8	5.0"	MS-300	8
3-1/2"	4.000"	6"	6.065"	MS-315	10	6.0"	MS-315	10
4"	4.500"	6"	6.065"	MS-300	10	6.0"	MS-300	10

Intermediate Metal Conduit (IMC)

Nominal Conduit Size	Actual O.D. Inches	Standard Weight Steel or PVC Pipe Sleeve*				Cast or core bit drilled hole*		
		Sleeve Nominal Pipe Size	Sleeve Actual I.D.	MetraSeal Model no.	Number of links required	Hole I.D.	MetraSeal Model no.	Number of links required
1/2"	.815"	2"	2.067"	MS-200	4	2.0"	MS-200	4
3/4"	1.029"	2"	2.067"	MS-200	4	2.5"	MS-275	6
1"	1.290"	2-1/2"	2.469"	MS-275	6	3.0"	MS-300	4
1-1/4"	1.638"	3-1/2"	3.548"	MS-315	5	3.0"	MS-275	7
1-1/2"	1.883"	3-1/2"	3.548"	MS-300	5	3.5"	MS-300	5
2"	2.360"	4"	4.026"	MS-300	6	4.0"	MS-300	6
2-1/2"	2.857"	4"	4.026"	MS-200	9	4.0"	MS-200	9
3"	3.476"	5"	5.047"	MS-360	7	5.0"	MS-300	8
3-1/2"	3.971"	6"	6.065"	MS-340	9	6.0"	MS-325	5
4"	4.466"	6"	6.065"	MS-300	10	6.0"	MS-300	10

*Minimum recommended sleeve length or wall thickness is 4" for MetraSeal model 325 and smaller and 6" for models 400 and larger.

If you do not see your pipe/hole combination, see page 10 or the web seal calculator at <http://www.metroflex.com/metraseal>

METRASEAL SELECTION CHARTS

Rigid Steel Conduit (RSC)

Nominal Conduit Size	Actual O.D. Inches	Standard Weight Steel or PVC Pipe Sleeve*				Cast or core bit drilled hole*		
		Sleeve Nominal Pipe Size	Sleeve Actual I.D.	MetraSeal Model no.	Number of links required	Hole I.D.	MetraSeal Model no.	Number of links required
1/2"	.840"	2"	2.067"	MS-200	4	2.0"	MS-200	4
3/4"	1.050"	2-1/2"	2.469"	MS-275	6	2.5"	MS-275	6
1"	1.315"	2-1/2"	2.469"	MS-200	5	3.0"	MS-300	4
1-1/4"	1.660"	3-1/2"	3.548"	MS-315	5	3.0"	MS-275	7
1-1/2"	1.900"	3-1/2"	3.548"	MS-300	5	3.5"	MS-300	5
2"	2.375"	4"	4.026"	MS-300	6	4.0"	MS-300	6
2-1/2"	2.875"	4"	4.026"	MS-200	9	4.0"	MS-200	9
3"	3.500"	5"	5.047"	MS-300	8	5.0"	MS-300	8
3-1/2"	4.000"	6"	6.065"	MS-340	9	6.0"	MS-325	5
4"	4.500"	6"	6.065"	MS-300	10	6.0"	MS-300	10
5"	5.563"	8"	7.981"	MS-425	6	8.0"	MS-425	6
6"	6.625"	8"	7.981"	MS-300	15	10.0"	MS-475	10

Ductile Iron Pipe (AWWA-Type)

Nominal Pipe Size	Actual Pipe O.D.	Standard Weight Steel or PVC Pipe Sleeve*				Cast or core bit drilled hole*		
		Sleeve Nominal Pipe Size	Sleeve Actual I.D.	MetraSeal Model no.	Number of links required	Hole I.D.	MetraSeal Model no.	Number of links required
2"	2.500"	3-1/2"	3.548"	MS-200	8	4.0"	MS-300	6
2-1/4"	2.750"	5"	5.047"	MS-340	7	5.0"	MS-340	7
3"	3.960"	6"	6.065"	MS-315	10	6.0"	MS-315	10
4"	4.800"	8"	7.981"	MS-410	7	8.0"	MS-410	7
6"	6.900"	10"	10.02"	MS-410	10	10.0"	MS-410	10
8"	9.050"	12"	12.00"	MS-400	9	12.0"	MS-400	9
10"	11.100"	14"	13.25"	MS-340	24	14.0"	MS-400	10
12"	13.200"	16"	15.25"	MS-325	14	16.0"	MS-360	21
14"	15.300"	18"	17.25"	MS-325	16	18.0"	MS-360	24
16"	17.400"	20"	19.25"	MS-315	39	20.0"	MS-360	27
18"	19.500"	24"	23.25"	MS-475	25	24.0"	MS-525	17
20"	21.600"	26"	25.25"	MS-475	28	26.0"	MS-525	19
24"	25.800"	30"	29.25"	MS-475	32	28.0"	MS-340	53
30"	32.000"	36"	35.25"	MS-475	40	36.0"	MS-575	34
36"	38.300"	42"	41.25"	MS-400	34	42.0"	MS-475	47
42"	44.500"	50"	49.25"	MS-500	38	50.0"	MS-500	38
48"	50.800"	54"	53.25"	MS-425	45	56.0"	MS-500	43

*Minimum recommended sleeve length or wall thickness is 4" for MetraSeal model 325 and smaller and 6" for models 400 and larger.

If you do not see your pipe/hole combination, see page 10 or the web seal calculator at

<http://www.metroflex.com/metraseal>

METRASEAL SELECTION CHARTS

Cast Iron Soil Pipe (Extra Heavy)

Nominal Pipe Size	Actual Pipe O.D.	Standard Weight Steel or PVC Pipe Sleeve*				Cast or core bit drilled hole*		
		Sleeve Nominal Pipe Size	Sleeve Actual I.D.	MetraSeal Model no.	Number of links required	Hole I.D.	MetraSeal Model no.	Number of links required
2"	2.380"	3-1/2"	3.548"	MS-200	8	4.0"	MS-300	6
3"	3.500"	5"	5.047"	MS-300	8	5.0"	MS-300	8
4"	4.500"	6"	6.065"	MS-300	10	6.0"	MS-300	10
5"	5.500"	8"	7.981"	MS-340	13	8.0"	MS-340	13
6"	6.500"	10"	10.02"	MS-475	9	10.0"	MS-475	9
8"	8.620"	12"	12.00"	MS-475	12	12.0"	MS-475	12
10"	10.750"	14"	13.25"	MS-425	10	14.0"	MS-475	14
12"	12.750"	16"	15.25"	MS-425	12	16.0"	MS-475	17
15"	15.880"	20"	19.25"	MS-475	21	18.0"	MS-340	33

Cast Iron Soil Pipe (Service Weight)

Nominal Pipe Size	Actual Pipe O.D.	Standard Weight Steel or PVC Pipe Sleeve*				Cast or core bit drilled hole*		
		Sleeve Nominal Pipe Size	Sleeve Actual I.D.	MetraSeal Model no.	Number of links required	Hole I.D.	MetraSeal Model no.	Number of links required
2"	2.300"	4"	4.026"	MS-315	6	4.0"	MS-315	6
3"	3.300"	5"	5.047"	MS-315	9	5.0"	MS-315	8
4"	4.300"	6"	6.065"	MS-315	11	6.0"	MS-315	11
5"	5.300"	8"	7.981"	MS-360	10	8.0"	MS-360	10
6"	6.300"	8"	7.981"	MS-315	15	8.0"	MS-315	15
8"	8.380"	12"	12.00"	MS-475	12	12.0"	MS-475	12
10"	10.500"	14"	13.25"	MS-360	17	14.0"	MS-475	14
12"	12.500"	16"	15.25"	MS-360	20	16.0"	MS-475	17
15"	15.620"	20"	19.25"	MS-475	20	18.0"	MS-425	14

*Minimum recommended sleeve length or wall thickness is 4" for MetraSeal model 325 and smaller and 6" for models 400 and larger.

If you do not see your pipe/hole combination, see page 10 or the web seal calculator at <http://www.metroflex.com/metraseal>

METRASeal SIZING CALCULATION

Use the following calculation method if you cannot find your pipe size or wall sleeve in the charts on pages 6, 7, 8 and 9 OR use the web seal calculator at <http://www.metroflex.com/metraseal-calculator>

Step 1 - Calculate the Annular Space

The Annular Space is the space between the Outside Diameter of the pipe, and the Inside Diameter of the wall sleeve or wall opening. It is calculated using the following formula:

$$\text{Annular Space} = \frac{\text{Wall Opening I.D.} - \text{Pipe O.D.}}{2}$$

Step 2 - Select MetraSeal Model

Select the proper MetraSeal Model from the MetraSeal Dimensional Chart (shown below) by comparing the Annular Space to the Free State and Expanded State Thicknesses. The Annular Space calculated must fall between the Free State and Expanded State Thicknesses.

Step 3 - Calculate Number of Links

First, calculate the Bolt Circle.

$$\text{Bolt Circle} = \frac{\text{Wall Opening I.D.} + \text{Pipe O.D.}}{2}$$

Then, determine the number of links required by using the following formula. Chord Length is found in MetraSeal Dimensional Chart below.

$$\text{Number of Links} = \frac{\text{Bolt Circle} \times 3.14}{\text{Chord Length}}$$

Finally, the number of links determined must be rounded down to the next whole number.

MetraSeal Dimensional Chart

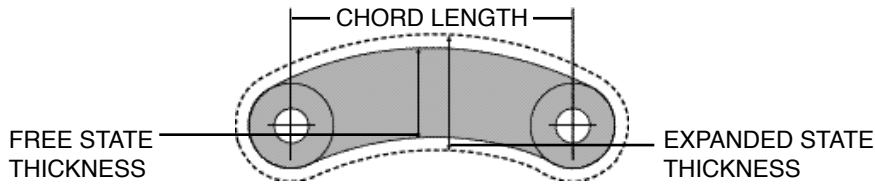

SEALING RANGE			
SIZE	FREE STATE THICKNESS	EXPANDED STATE THICKNESS	CHORD LENGTH
MS-200	.50"	.62"	1.125"
MS-275	.62"	.78"	0.910"
MS-300	.71"	.88"	1.510"
MS-315	.82"	1.03"	1.470"
MS-325	.94"	1.18"	3.100"
MS-340	1.05"	1.33"	1.575"
MS-360	1.29"	1.65"	2.106"
MS-400	1.43"	1.81"	3.625"
MS-410	1.48"	1.91"	2.598"
MS-425	1.13"	1.45"	3.625"
MS-475	1.62"	1.90"	2.625"
MS-500	2.37"	2.81"	3.860"
MS-525	2.18"	2.50"	3.860"
MS-575	1.81"	2.35"	3.100"
MS-600	3.20"	4.00"	6.000"

Or use the web seal calculator at <http://www.metroflex.com/metraseal-calculator>

TYPE	SEAL MATERIAL	PRESSURE PLATES	BOLTS & NUTS	TEMPERATURE RANGE(F)
E	EPDM Black	Glass reinforced plastic	Steel Zinc Dichromate	-40 to +250
ES	EPDM Black	Glass reinforced plastic	Stainless Steel (316)	-40 to +250
P	Nitrile Black	Glass reinforced plastic	Steel Zinc Dichromate	-40 to +210
PS	Nitrile Black	Glass reinforced plastic	Stainless Steel (316)	-40 to +210
HT	Silicone Gray	Steel Zinc Dichromate	Steel Zinc Dichromate	-40 to +400

NOTE: MAX SEALING PRESSURE OF 20 PSIG AND 40 FT. HEAD

ALL DIMENSIONS ARE IN INCHES

DIMENSIONAL DATA			
MODEL #	FREE STATE THICKNESS	EXPANDED STATE THICKNESS	CHORD LENGTH
MS-200	.50	.62	1.125
MS-275	.62	.78	.910
MS-300	.71	.88	1.510
MS-315	.82	1.03	1.470
MS-325	.94	1.18	3.100
MS-340	1.05	1.33	1.575
MS-360	1.29	1.65	2.106
MS-400	1.43	1.81	3.625
MS-410	1.48	1.91	2.598
MS-425	1.13	1.45	3.625
MS-475	1.62	1.90	2.625
MS-500	2.37	2.81	3.860
MS-525	2.18	2.50	3.860
MS-575	1.81	2.35	3.100
MS-600	3.20	4.00	6.000

*FOR SIZING INFORMATION SEE METRASEAL SELECTION CHARTS
<http://www.metroflex.com/metraseal>

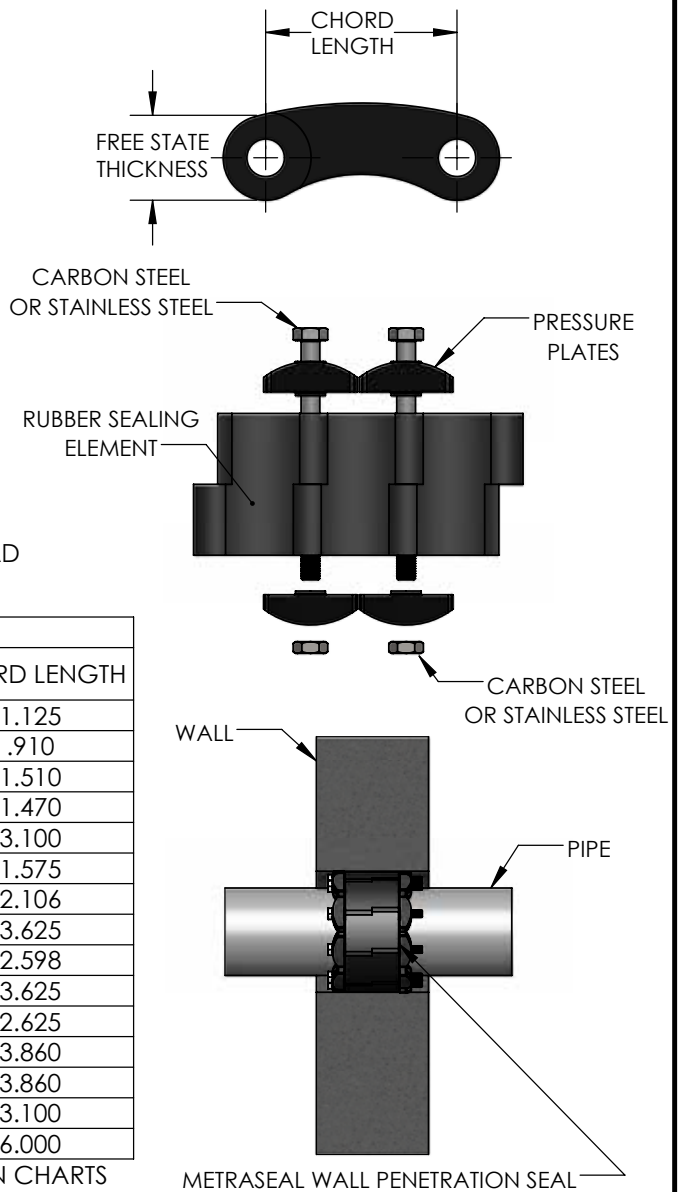

NOMINAL PIPE SIZE & TYPE OF PIPE	PIPE O.D.	INNER PIPE THROUGH A CORE DRILLED HOLE			INNER PIPE THROUGH A WALL SLEEVE			NOTES
		HOLE DIA.	MODEL NO./TYPE	QTY. OF LINKS	SLEEVE I.D.	MODEL NO./TYPE	QTY. OF LINKS	

NSF 372 - LEAD FREE
 The wetted surface of this product contacted by consumable water contains less than one quarter of one percent (0.25%) of lead by weight. Material complies with state codes and standards, where applicable, requiring reduced lead content.

CUSTOMER: _____
 PROJECT: _____
 ENGINEER: _____

REV.	DATE
2323 W. HUBBARD ST. CHICAGO, IL 60612 TEL: 312-738-3800 FAX: 312-738-0415 WWW.METRAFLEX.COM	
DRAWN BY: JW	DATE: 5/22/2015
APPROVED: ZB	DATE: 5/22/2015
SCALE: N/A	DRAWING NUMBER: SEAL

WALL SLEEVES

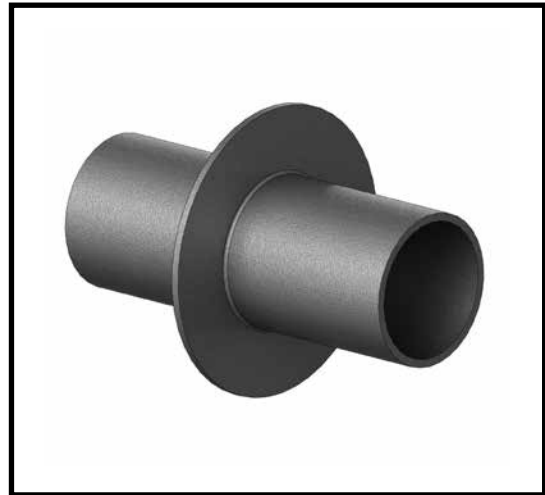
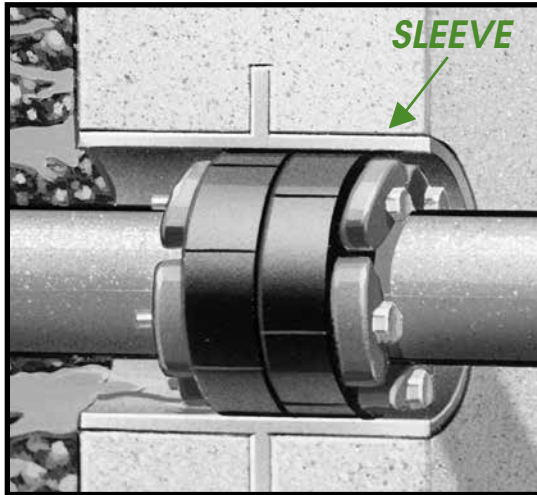

Wall Sleeves must be positioned in the wall before the concrete is poured.

Standard Weight steel or PVC pipe sleeve			
Sleeve Nominal Pipe Size	Sleeve Actual I.D.	Standard Sleeve Length*	Standard Water-stop Height*
2"	2.067"	12"	2"
2.5"	2.469"	12"	2"
3"	3.068"	12"	2"
3.5"	3.548"	12"	2"
4"	4.026"	12"	2"
5"	5.047"	12"	2"
6"	6.065"	12"	2"
8"	7.981"	12"	2"
10"	10.02"	12"	2"
12"	12.00"	12"	2"
14"	13.25"	12"	2"
16"	15.25"	12"	2"
18"	17.25"	12"	2"
20"	19.25"	12"	2"
22"	21.25"	12"	2"
24"	23.25"	12"	2"
26"	25.25"	12"	2"
28"	27.25"	12"	2"
30"	29.25"	12"	2"
32"	31.25"	12"	2"
34"	33.25"	12"	2"
36"	35.25"	12"	2"
38"	37.25"	12"	2"
40"	39.25"	12"	2"
42"	41.25"	12"	2"
44"	43.25"	12"	2"
46"	45.25"	12"	2"
48"	47.25"	12"	2"
50"	49.25"	12"	2"
52"	51.25"	12"	2"
54"	53.25"	12"	2"

*Optional lengths and heights available. Please contact your Metraflex representatives.

Terms and Conditions

1. All quotations are subject to approval, acceptance and correction at the home office. Any errors in quotations resulting in orders will be corrected and submitted to the customer for their acceptance or refusal.

No prices may be made up from information other than that shown in the tables.

2. All prices are F.O.B. factory, Chicago, Illinois, and are quoted exclusive of any taxes.

Shipments boxed for trans-ocean export, add 10% to total trade prices.

Terms: Net 30 days from date of invoice.

3. Cancellation or alteration of an order or return of any product by Buyer may not be made without advance written consent of manufacturer and shall be subject to a cancellation charge. Custom products are not returnable.

A 35% minimum restocking charge shall be placed on any returned goods, or a \$25.00 charge (whichever is greater).

4. We will not be responsible for delays in shipping due to conditions beyond our control such as strikes, fires, or accidents.

5. Any claims for shortages or damaged products must be made in writing within 10 days after receipt of shipment.

6. Prices subject to change without notice.

Design and Dimensional Specifications

The products illustrated reflect the design characteristics at time of printing.

Metraflex reserves the right to change dimensions, material, or methods of construction without notice. Please contact the factory for certified prints (exact dimensions) when necessary.

Limited Warranty

All products are warranted to be free of defects in material and workmanship for a period of one year from the date of shipment, subject to the limitations below.

If the purchaser believes a product is defective the purchaser shall: (a) Notify the manufacturer, state the alleged defect and request permission to return the product. (b) If permission is given, return the product with transportation prepaid. If the product is accepted for return and found to be defective, the manufacturer will, at its discretion, either repair or replace the product, F.O.B. factory, within 60 days of receipt, or refund the purchase price. Other than to repair, replace or refund as described above, purchaser agrees that manufacturer shall not be liable for any loss, costs, expenses or damages of any kind arising out of the product, its uses, installation or replacement, labeling, instructions information or technical data of any kind, description of product or use, samples or model, warnings or lack of any of

the foregoing. NO OTHER WARRANTIES, WRITTEN OR ORAL, EXPRESS OR IMPLIED, INCLUDING THE WARRANTIES OF FITNESS FOR A PARTICULAR PURPOSE AND MERCHANTABILITY, ARE MADE OR AUTHORIZED. NO AFFIRMATION OF FACT, PROMISE, DESCRIPTION OF PRODUCT OF USE OR SAMPLE OR MODEL SHALL CREATE ANY WARRANTY FROM MANUFACTURER, UNLESS SIGNED BY THE PRESIDENT OF MANUFACTURING. These products are not manufactured, sold or intended for personal, family or household purposes.

METRASEAL

For a fast, permanent seal



OFF CENTER SEAL

The seal for holes that aren't quite perfect...



MODULAR RISER GUIDE

The riser pipe guide for pipes in motion



HIGH/LOW TEMPERATURE,
LOW DUROMETER SEAL

High and low temperature silicone MetraSeal pipe penetration seals withstand extreme temperatures.

Rated at -40° to 400° F.

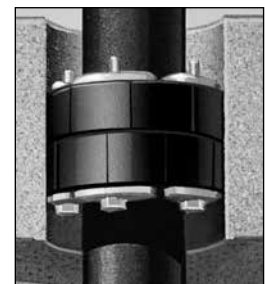

**Contact Metraflex
or your local rep
for additional brochures
800-621-4347
or visit
<http://www.metraflex.com/seals>**

"Oh, S#!T...It doesn't fit..."



IT DOES NOW!!



OFF CENTER SEALS

From the Leader in Seal Innovations

The **Metraflex** Company
for pipes in motion

©2003 The Metraflex Company

www.metraflex.com/seal

Enter the following information into the website
Off Center Seal Calculator:

- 1 The closest dimension of the pipe to the Hole ID
- 2 Pipe OD
- 3 Hole ID

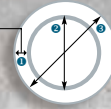

There are millions of offset pipe combinations. Only with the Off Center Seal calculator is it possible to configure the unique sizes needed for your application. Print the results and fax or e-mail it to your local Metraflex representative.

In addition to these seals Metraflex has a complete line of:

- ✓ Water Tight Wall Penetration Seals
- ✓ Firestopping Seals
- ✓ Sliding Seals that Seal and Allow for Pipe Movement

The **Metraflex** Company
for pipes in motion

The Metraflex Company • 2323 W. Hubbard St. • Chicago, IL 60612 • Tel: 800-621-4347 • Fax: 312-738-0415 • www.metraflex.com

MODULAR RISER GUIDE™

VIBRATION ISOLATION PIPE GUIDE FOR RISERS

Now isolate 52%
of transmitted
noise with the
compact Modular
Riser Guide



Turns holes into
pipe guides!

The **Metraflex** Company
for pipes in motion

www.metraflex.com

2323 W. HUBBARD ST • CHICAGO, IL 60612 • 800-621-4347 • 312-738-3800 • FAX 312-738-0415 • www.metraflex.com

The Modular Riser Guide

In-the-hole pipe guide isolates 52% of transmitted noise

Unique slide
surface allows
unlimited axial
movement

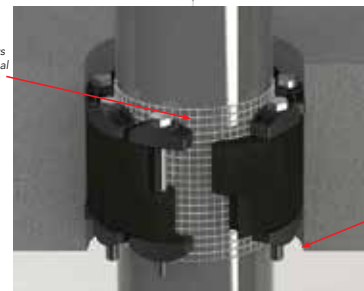

Core-drilled or
sleeved hole

Unlimited axial movement in the tightest spaces!

The redesigned Modular Riser Guide allows unlimited axial pipe movement. It quickly fastens around the pipe, fills the annular gap and can be installed in a riser.

Its modular design allows for a quick installation in very tight spaces by utilizing existing floor penetrations.

Ease of installation - no more welding or drilling through concrete - simply use the existing hole, wrap the modular belt with a friction reducing layer around the pipe, fasten a few bolts, and walk away!

The lateral stability protects the expansion joint against squirm.

Creating a water resistant seal for temperature applications up to 250°F, the Modular Riser Guide can guide any size pipe.

Features/Benefits

- Unlimited axial movement
- Faster install time
- No more welding or fastening to external surfaces
- Vibration dampening
- Noise isolation
- Install around any round pipe

Independent testing shows the rubber sealing element eliminates up to 52% vibration, and protects the building's occupants from the unwanted noise & vibration.



The **Metraflex** Company
for pipes in motion

2323 W. HUBBARD ST • CHICAGO, IL 60612 • 800-621-4347 • 312-738-3800 • FAX 312-738-0415 • www.metraflex.com

Catalog Modular Riser Guide 1215

© THE METRAFLEX CO. 2015. All rights reserved

Printed in U.S.A.

For more information visit <http://www.metraflex.com/seals>

METRASEAL

PIPE WALL PENETRATION SEALS

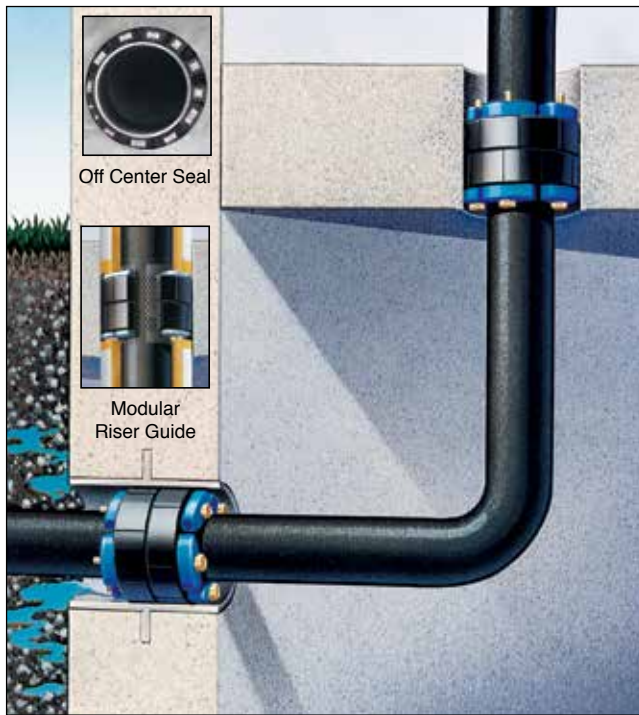

Download the MetraSeal App



Scan me for iPhone



Scan me for Android

ABOUT METRAFLEX

“For Pipes in Motion” founded in 1958, Metraflex offers a wide range of products for the piping trades. Vibration isolation, thermal and seismic movement have been at the forefront of Metraflex’s R&D efforts.

www.metraflex.com • 800-621-4347
2323 W Hubbard St • Chicago • Illinois • 60612



For more information visit <http://www.metraflex.com/seals>