

***Max Operating Conditions**

Temp. (°F)	Pressure (PSI)
170°	225
180°	200
190°	175
200°	150
210°	125
220°	100
230°	75

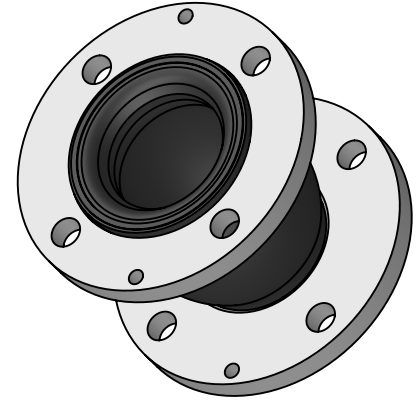

MAXIMUM WORKING TEMPERATURE 230°F

LEAD FREE

The wetted surface of this product contacted by consumable water contains less than one quarter of one percent (0.25%) of lead by weight. Material complies with state codes and standards, where applicable, requiring reduced lead content.

Notes:

For installation instructions go to www.metroflex.com. Joint must be installed at its neutral length, and the bolts properly torqued. Not suitable for steam or vacuum applications. If connecting pipe is not anchored and guided, control units must be used. Contact factory for other sizes.

TO BE FURNISHED WITH CONTROL UNITS:

YES

NO

ITEM	PART NAME	MATERIAL
1	COVER	EPDM
2	TUBE	EPDM
3	ANCHOR WIRE	GALV. STEEL
4	FLANGE	GALV. STEEL, 150#, DRILLED

*EPDM is the standard elastomer for the interior and exterior covering. Contact factory for other elastomers.

MOVEMENT CAPABILITY AND FORCES

Qty.	Part Number	Size I.D. (in)	F/F (in)	AXIAL			DEFLECTION			Weight (Lbs)	Hole Size	
				Comp. (in)	Approx Force (Lbs)	Elong. (in)	Approx Force (Lbs)	Lateral (in)	Approx Force (Lbs)			Angular (Deg)
	MSRDEE0200	2	6	0.5	55	0.375	73	0.5	55	15	8	0.75
	MSRDEE0250	2.5	6	0.5	102	0.375	68	0.5	97	15	13	0.75
	MSRDEE0300	3	6	0.5	136	0.375	115	0.5	108	15	14	0.75
	MSRDEE0400	4	6	0.625	145	0.375	242	0.5	275	15	18	0.75
	MSRDEE0500	5	6	0.625	172	0.375	196	0.5	308	15	23	0.875
	MSRDEE0600	6	6	0.625	293	0.375	563	0.5	484	15	28	0.875
	MSRDEE0800	8	6	0.625	372	0.5	587	0.5	688	15	40	0.875

SUBMITTAL FOR SIZES 10 - 24 ALSO AVAILABLE ON METRAFLEX.COM

PROJECT INFO

CUSTOMER: _____

PROJECT: _____

ENGINEER: _____

REV.	DATE
2323 W. HUBBARD ST. CHICAGO, IL 60612 TEL: 312-738-3800 FAX: 312-738-0415 WWW.METRAFLEX.COM	
METRASPHERE STYLE "R" EPDM DRILLED SPHERICAL CONNECTOR	
DRAWN BY: DKISH	DATE: 11/5/2014
APPROVED: JC	DATE: 11/5/2014
SCALE: NONE	DRAWING NUMBER: MSR-EE-D 2-8

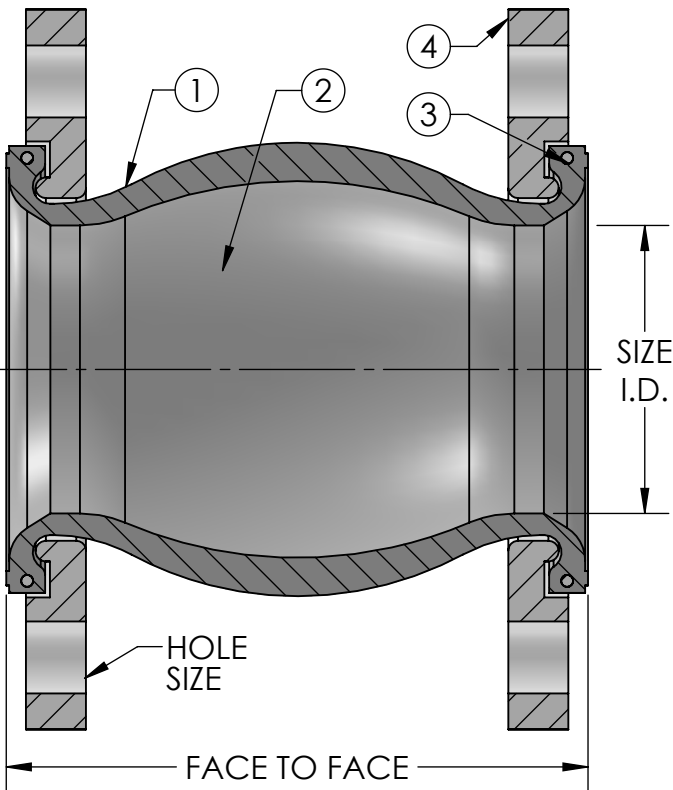

***Max Operating Conditions**

Temp (F)	Pressure (PSI)	
	10" - 12"	14" - 24"
170°	225	125
180°	200	115
190°	175	105
200°	150	95
210°	125	40
220°	100	35
230°	75	25

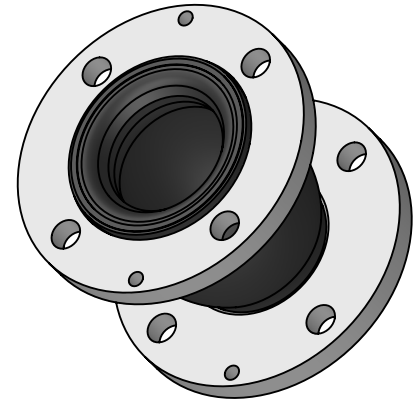

MAXIMUM WORKING TEMPERATURE 230°F

LEAD FREE

The wetted surface of this product contacted by consumable water contains less than one quarter of one percent (0.25%) of lead by weight. Material complies with state codes and standards, where applicable, requiring reduced lead content.

Notes:

For installation instructions go to www.metroflex.com. Joint must be installed at its neutral length, and the bolts properly torqued. Not suitable for steam or vacuum applications. If connecting pipe is not anchored and guided, control units must be used. Contact factory for other sizes.

TO BE FURNISHED WITH CONTROL UNITS:

YES

NO

ITEM	PART NAME	MATERIAL
1	COVER	EPDM
2	TUBE	EPDM
3	ANCHOR WIRE	GALV. STEEL
4	FLANGE	GALV. STEEL, 150#, DRILLED

*EPDM is the standard elastomer for the interior and exterior covering. Contact factory for other elastomers.

MOVEMENT CAPABILITY AND FORCES

Qty.	Part Number	Size I.D. (in)	F/F (in)	AXIAL			DEFLECTION			Weight (Lbs)	Hole Size	
				Comp. (in)	Approx Force (Lbs)	Elong. (in)	Approx Force (Lbs)	Lateral (in)	Approx Force (Lbs)			Angular (Deg)
	MSRDEE1000	10	8	0.75	398	0.5	455	0.75	781	15	68	1
	MSRDEE1200	12	8	0.75	390	0.5	356	0.75	842	15	94	1
	MSRDEE1400	14	8	0.75	N/A	0.5	N/A	0.75	N/A	15	105	1.125
	MSRDEE1600	16	8	0.75	N/A	0.5	N/A	0.75	N/A	15	120	1.125
	MSRDEE1800	18	8	0.75	N/A	0.5	N/A	0.75	N/A	15	125	1.25
	MSRDEE2000	20	8	0.75	N/A	0.5	N/A	0.75	N/A	15	145	1.25
	MSRDEE2400	24	10	0.75	N/A	0.5	N/A	0.75	N/A	15	165	1.375

SUBMITTAL FOR SIZES 2 - 8 ALSO AVAILABLE ON METRAFLEX.COM

PROJECT INFO

CUSTOMER: _____

PROJECT: _____

ENGINEER: _____

REV.	DATE
2323 W. HUBBARD ST. CHICAGO, IL 60612 TEL: 312-738-3800 FAX: 312-738-0415 WWW.METRAFLEX.COM	
METRASPHERE STYLE "R" EPDM DRILLED SPHERICAL CONNECTOR	
DRAWN BY: DKISH	DATE: 11/5/2014
APPROVED: JC	DATE: 11/5/2014
SCALE: NONE	DRAWING NUMBER: MSR-EE-D 10-24