

***Max Operating Conditions**

Temp. (°F)	Pressure (PSI)
170°	225
180°	200
190°	175
200°	150
210°	125
220°	100
230°	75

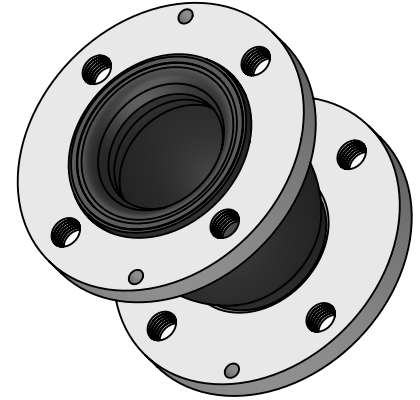

MAXIMUM WORKING TEMPERATURE 230°F

LEAD FREE

The wetted surface of this product contacted by consumable water contains less than one quarter of one percent (0.25%) of lead by weight. Material complies with state codes and standards, where applicable, requiring reduced lead content.

Notes:

For installation instructions go to www.metroflex.com. Joint must be installed at its neutral length, and the bolts properly torqued. Not suitable for steam or vacuum applications. If connecting pipe is not anchored and guided, control units must be used. Contact factory for other sizes.

TO BE FURNISHED WITH CONTROL UNITS:

YES

NO

ITEM	PART NAME	MATERIAL
1	COVER	EPDM
2	TUBE	EPDM
3	ANCHOR WIRE	GALV. STEEL
4	FLANGE	GALV. STEEL, 150#, TAPPED

*EPDM is the standard elastomer for the interior and exterior covering. Contact factory for other elastomers.

MOVEMENT CAPABILITY AND FORCES

Qty.	Part Number	Size I.D. (in)	F/F (in)	AXIAL			DEFLECTION			Weight (Lbs)	Thread Size UNC	
				Comp. (in)	Approx Force (Lbs)	Elong. (in)	Approx Force (Lbs)	Lateral (in)	Approx Force (Lbs)			Angular (Deg)
	MSOEE0100	1	3.75	0.25	N/A	0.0937	N/A	0.25	N/A	15	5	0.5
	MSOEE0125	1.25	3.75	0.25	N/A	0.0937	N/A	0.25	N/A	15	6	0.5
	MSOEE0150	1.5	3.75	0.25	N/A	0.0937	N/A	0.25	N/A	15	7	0.5
	MSOEE0200	2	4.125	0.375	55	0.25	73	0.375	55	15	8	0.625
	MSOEE0250	2.5	4.5	0.5	102	0.25	68	0.375	97	15	13	0.625
	MSOEE0300	3	5.125	0.5	136	0.25	115	0.375	108	15	14	0.625
	MSOEE0400	4	5.375	0.75	145	0.375	242	0.5	275	15	18	0.625
	MSOEE0500	5	6.75	0.75	172	0.375	196	0.5	308	15	23	0.75
	MSOEE0600	6	7.125	0.75	293	0.375	563	0.5	484	15	28	0.75
	MSOEE0800	8	8.125	1	372	0.5	587	0.875	688	15	40	0.75
	MSOEE1000	10	9.375	1	398	0.5	455	0.875	781	15	68	0.875
	MSOEE1200	12	10.25	1	390	0.5	356	0.875	842	15	94	0.875

PROJECT INFO

CUSTOMER: _____

PROJECT: _____

ENGINEER: _____

REV.

DATE



2323 W. HUBBARD ST.
CHICAGO, IL 60612
TEL: 312-738-3800
FAX: 312-738-0415
WWW.METRAFLEX.COM

METRASPHERE STYLE "O"
EPDM TAPPED SPHERICAL CONNECTOR

DRAWN BY: **DKISH**

DATE: **11/5/2014**

APPROVED: **JC**

DATE: **11/5/2014**

SCALE:

NONE

DRAWING NUMBER:

MSO-EE-T