

Model PA Anchor Clamp

Light weight anchor for low load. This anchor is ideal for the Metraloop expansion joint or other "no thrust" expansion joints. Clamps to pipe.

Feet can be bolted or welded to structure.

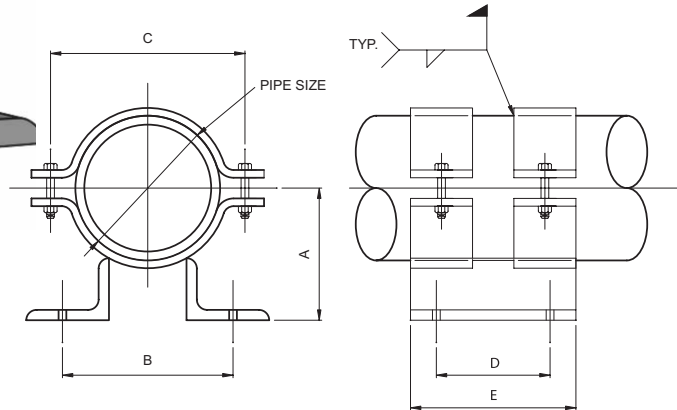

TOTAL QTY.	PIPE SIZE	A	B	C	D	E	BOLT HOLE	WEIGHT (LBS.)
	3/4"	2-1/8"	3-3/8"	3-5/8"	2-3/4"	4	5/8"	3
	1"	2-1/8"	3-3/8"	3-5/8"	2-3/4"	4	5/8"	3
	1-1/4"	2-3/8"	3-3/8"	3-5/8"	2-3/4"	4	5/8"	3
	1-1/2"	2-1/2"	3-3/8"	4-5/8"	2-3/4"	4	5/8"	4
	2"	2-3/4"	3-3/8"	4-5/8"	2-3/4"	4	5/8"	4
	2-1/2"	3"	3-3/8"	5-5/8"	2-3/4"	4	5/8"	4
	3"	3-1/4"	4-1/8"	5-5/8"	2-3/4"	4	5/8"	4
	4"	3-1/2"	5-1/8"	7-1/4"	2-3/4"	4	5/8"	5
	5"	4-1/2"	5-7/8"	8-1/2"	4	6	3/4"	7
	6"	5"	6-1/4"	8-1/2"	4	6	3/4"	8
	8"	6"	6-3/4"	10-7/8"	4	6	3/4"	9
	10"	7"	7-3/4"	12-5/8"	4	6	3/4"	14
	12"	8"	8-1/8"	14-3/4"	4	6	3/4"	16

Notes: Material - Carbon Steel. Finish - One Coat of Paint.

CUSTOMER _____

PROJECT _____

ENGINEER _____

ARCHITECT _____

PRO. OR P.O. NO _____



DESCRIPTION:

ANCHOR CLAMP

DRAWN BY:
KL

DATE:
1/05

DRAWING NO:
ACA5