

# METRALOOP<sup>®</sup>

## EXPANSION JOINT DESIGN GUIDE



- **NO THRUST LOADS**
  - **MINIMAL ANCHOR LOADS**
  - **MINIMAL GUIDING**
  - **SEISMIC RATINGS**

**Metraflex**<sup>®</sup>  
*for pipes in motion*



# THE METRALOOP® ADVANTAGE . . . . . . DESIGN FREEDOM!

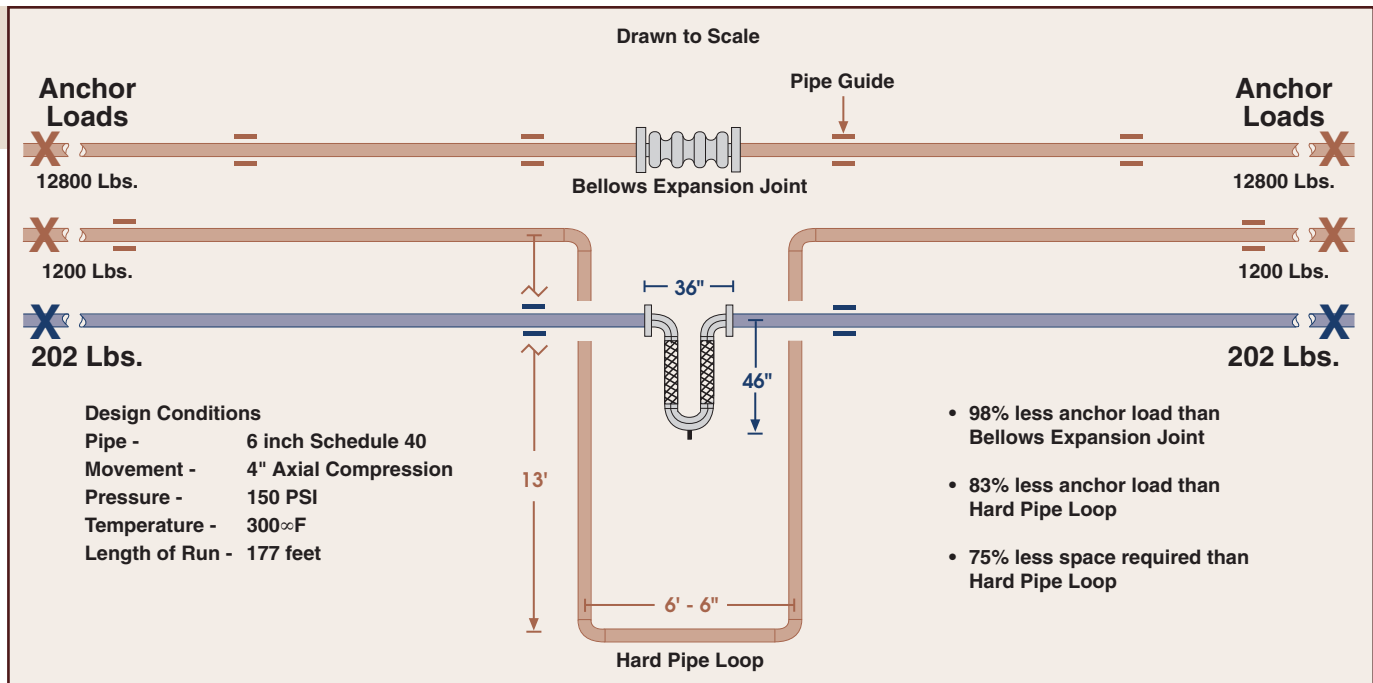

## YOUR FIRST CHOICE BECAUSE . . .

- Path of Least Resistance - which is why GUIDES are not always required. With an incredibly low force to compress, the Loop is the path of least resistance absorbing thermal movement before the pipe begins to bow. Long before thermal expansion develops enough force to start to compress traditional bellows type joints or hard pipe loops, the column loading strength of pipe is exceeded and the pipe begins to bow. Hence the need for numerous and specifically placed pipe guides up and down the pipe run in traditional piping systems.
- Anchor Loads - Almost None - compared to bellows or hard pipe loops. Bellows type joints exert tremendous anchor loads, requiring answers to: is the concrete thick enough, what size anchor bolts, is the steel strong enough, where do I make the attachments???. The MetraLoop anchor loads are so low; these questions may be immaterial.
- Amount of movement - virtually any. Stock sizes are shown on pages 4-5, however movements greater than 3 or 6 FEET! are not uncommon.

## BENEFITS:

- Movement in all directions - absorbing seismic energy with low activation forces, standard seismic bracing is adequate for adjacent piping. Ball or bellows joints have significant breakaway torques or thrust loads that exceed standard seismic bracing.
- Fire Sprinkler Systems - UL listed, the Fireloop provides seismic protection in a compact, easy to install component. See the Fireloop Design Guide or website [www.metroflex.com](http://www.metroflex.com) for full details.
- Gas - Protect against devastating fire by installing C.S.A./A.G.A. certified Metraloops in gas lines as they cross the building's seismic joints or at the connection to gas-fired equipment.
- Reduce Costs - Metraloops are far less expensive than alternative seismic expansion joints, particularly ball-joints.
- Protect Equipment - Metraloops allow equipment such as boilers and chillers to move independently from the building during an earthquake. Prevent nozzles from cracking or shearing in earthquakes by installing Metraloops at the connection.

**For Seismic Installations,  
see Page 11.**



# ALL METALLIC CONSTRUCTION



## TABLE OF CONTENTS

|   |                    |
|---|--------------------|
| MetraLoop Drawing .....                                     | Inside Front Cover |
| Seismic Benefits .....                                      | Inside Front Cover |
| Typical Specification .....                                 | 1                  |
| How the MetraLoop Works .....                               | 2                  |
| Typical Installations .....                                 | 3                  |
| MetraLoop Selection Chart - Sweat, Thread & Flanged Ends .. | 4                  |
| MetraLoop Selection Chart - Weld & Grooved Ends .....       | 5                  |
| Installation/Guiding Considerations .....                   | 6                  |
| Applications .....  | 7-9                |
| Thermal Expansion Applications .....                        | 10                 |
| Seismic Applications .....                                  | 11                 |
| Test Report .....   | 12                 |
| Pressure Drop Charts .....                                  | 13                 |
| MetraLoop Drawings .....                                    | 14-16              |
| Terms and Conditions .....                                  | 17                 |

## TYPICAL SPECIFICATION

Provide flexible expansion loops of size and type noted on drawings. Flexible loops shall consist of two flexible sections of hose and braid, two 90° elbows, and an 180° return assembled in such a way that the piping does not change direction, but maintains its course along a single axis. Flexible loops shall have a factory supplied, center support nut located at the bottom of the 180° return, and a drain/air release plug. Flexible loops shall impart no thrust loads to system support anchors or building structure. Loops shall be installed in a neutral, pre-compressed or pre-extended condition as required for the application. For steam service, loops must be installed with flexible legs horizontal to prevent condensate buildup. Install and guide per manufacturer's recommendations. Materials of construction and end fitting type shall be consistent with pipe material and equipment/pipe connection fittings. For natural gas service, connectors shall be A.G.A. certified. Flexible expansion loops to be "Metraloop"™ as manufactured by the Metraflex Company®, Chicago, IL.

# HOW THE METRALOOP WORKS

## THERMAL EXPANSION: AXIAL MOVEMENT

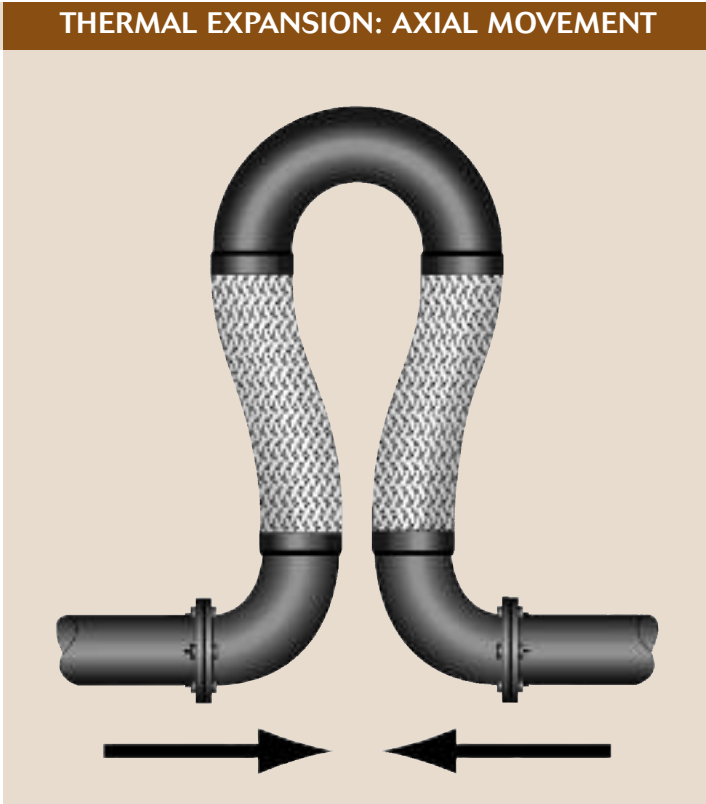

## SEISMIC MOVEMENT: ALL DIRECTIONAL

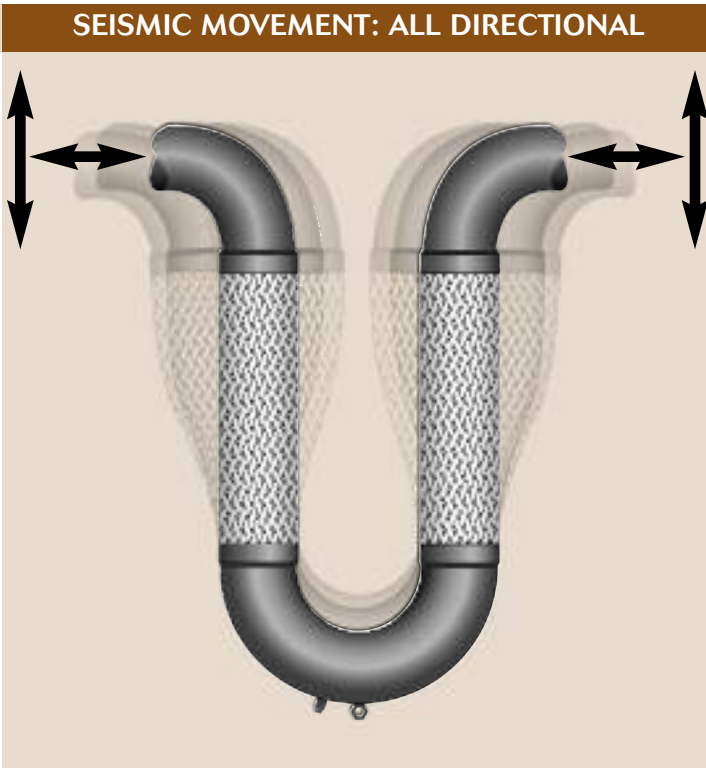

## THERMAL EXPANSION:

The MetraLoop is simply a flexible variation of the tradition hard pipe loop. For any given length of pipe and given temperature change, the amount of movement can be calculated and the appropriate MetraLoop can be designed. When installed in a pipe run the MetraLoop's legs simply bend laterally to compensate for the pipe's expansion or contraction. Unique to the loop is the incredibly low amount of force required to bend its legs, minimizing anchor loads, guiding and installation costs.

## SEISMIC MOVEMENT:

The two flexible legs connected by an unrestrained return bend, will allow a predetermined amount of pipe movement in any direction. (Typical design movement is  $\pm 4$  inches in any direction, however movement of several feet in any direction is possible). With the loops extreme flexibility and low force to move, the loop absorbs the seismic energy and imposes minimal loads on the adjacent pipe hangers, supports or nozzle loads on major equipment. See page 11 for more details.



# TYPICAL INSTALLATIONS

Illustrated below are the typical orientations for the MetraLoop. No support is required for the 180° return bend for standard loops 2-1/2" diameter and smaller. However due to the weight of the return bend and the extreme flexibility of the loop, larger sizes require support to prevent the 180 from sagging in all orientations except when installed hanging down as shown in illustration #2. Guides are recommended but not always required see bottom of page 6 for more details. **Special Note** - For steam service minimizing the entrapment of condensate is crucial and loops should be installed as shown in illustration #1. Detailed installation considerations are noted on the following pages.

## METRALOOP™ HORIZONTAL

– HORIZONTAL RUN –

#1

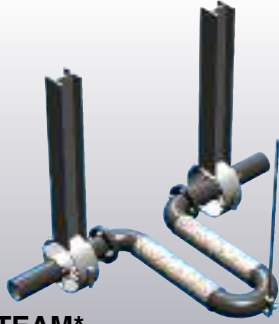

**STEAM\***

SUPPORT MUST BE PROVIDED TO PREVENT THE LOOP FROM DROOPING OR TORQUING PIPE. SUPPORT MUST ALLOW THE 180° RETURN, TO MOVE HORIZONTALLY BACK AND FORTH 1/4', AS THE LOOP FLEXES.

\*RECOMMENDED INSTALLATION FOR STEAM. ANY OTHER ORIENTATION MAY CAUSE CONDENSATE TO COLLECT.

## METRALOOP™ HANGING DOWN

– HORIZONTAL RUN –

#2



LOOP SHOULD HANG STRAIGHT DOWN AND BE FREE TO FLEX.

## METRALOOP™ STRAIGHT UP

– HORIZONTAL RUN –

#3

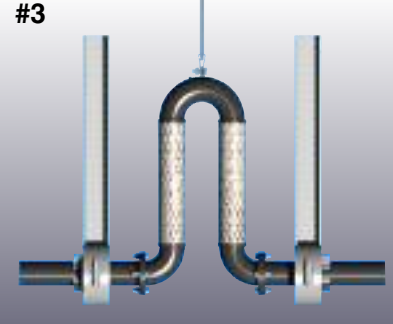

SUPPORT MUST BE PROVIDED TO PREVENT THE LOOP FROM LEANING. PIPE HANGER ROD SHOULD BE LOOSE ENOUGH TO ALLOW THE 180° RETURN TO MOVE UP OR DOWN, OR BACK AND FORTH, AS THE LOOP FLEXES.

## METRALOOP™ – NESTED –

#4



FOR TIGHT PIPE RUNS, ANY SIZE OR NUMBER OF LOOPS CAN BE DESIGNED TO NEST INSIDE ONE ANOTHER. TO ORDER, SPECIFY SEQUENCE OF PIPE DIAMETERS AND CORRESPONDING DISTANCES BETWEEN PIPE CENTERLINES.

## METRALOOP™ – VERTICAL RUN –

#5



LOOP MUST BE SUPPORTED TO ALLOW THE 180° RETURN TO MOVE HORIZONTALLY BACK AND FORTH, AND UP OR DOWN, AS THE LOOP FLEXES.

## METRALOOP™ – OVER/UNDER –

#6

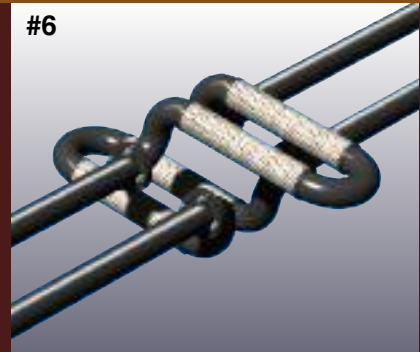

THE METRALOOP EXPANSION LOOP CAN BE MANUFACTURED IN THIS CONFIGURATION TO BE AS COMPACT AS POSSIBLE. MULTIPLE OVER-UNDER LOOPS CAN ALSO BE INSTALLED IN NESTED CLUSTERS TO FURTHER TAKE ADVANTAGE OF THIS COMPACT ARRANGEMENT.

# METRALOOP SELECTION CHART

## SWEAT ENDS - FEMALE • FITTINGS - COPPER • HOSE & BRAID - BRONZE

| PIPE SIZE     | MODEL #  | MOVEMENT | END TO END | LENGTH  | PSI SINGLE BRAID | †PSI DOUBLE BRAID | *SPRING FORCE LBS. | WEIGHT LBS. |
|---------------|----------|----------|------------|---------|------------------|-------------------|--------------------|-------------|
| 1/2" (15mm)   | MLS30050 | ±1.5"    | 5"         | 11-1/2" | 706              | 1130              | 45                 | 2           |
|               | MLS80050 | ±4"      | 8"         | 15-3/8" |                  |                   |                    | 2.5         |
| 3/4" (20mm)   | MLS30075 | ±1.5"    | 6"         | 13-1/8" | 577              | 923               | 47                 | 2           |
|               | MLS80075 | ±4"      | 9-1/2"     | 17-1/4" |                  |                   |                    | 2.5         |
| 1" (25mm)     | MLS30100 | ±1.5"    | 6-1/2"     | 14-5/8" | 470              | 752               | 53                 | 2.5         |
|               | MLS80100 | ±4"      | 10-1/4"    | 19-1/4" |                  |                   |                    | 3           |
| 1-1/4" (30mm) | MLS30125 | ±1.5"    | 7-3/4"     | 16-3/8" | 361              | 577               | 66                 | 3.5         |
|               | MLS80125 | ±4"      | 11-1/4"    | 21-3/8" |                  |                   |                    | 4           |
| 1-1/2" (40mm) | MLS30150 | ±1.5"    | 9-1/4"     | 17-1/4" | 329              | 526               | 70                 | 4           |
|               | MLS80150 | ±4"      | 11-3/4"    | 22-1/2" |                  |                   |                    | 4.5         |
| 2" (50mm)     | MLS30200 | ±1.5"    | 11-1/4"    | 18-3/4" | 317              | 507               | 78                 | 9           |
|               | MLS80200 | ±4"      | 14"        | 24-3/4" |                  |                   |                    | 12          |
| 2-1/2" (65mm) | MLS30250 | ±1.5"    | 13"        | 19-3/4" | 272              | 435               | 83                 | 12          |
|               | MLS80250 | ±4"      | 15"        | 26-1/2" |                  |                   |                    | 18          |
| 3" (80mm)     | MLS30300 | ±1.5"    | 14"        | 21-1/2" | 201              | 322               | 90                 | 18          |
|               | MLS80300 | ±4"      | 16-1/2"    | 28-1/2" |                  |                   |                    | 24          |
| 4" (100mm)    | MLS30400 | ±1.5"    | 18"        | 24-3/4" | 142              | 227               | 120                | 26          |
|               | MLS80400 | ±4"      | 22"        | 32"     |                  |                   |                    | 31          |

Pressure ratings reflect standard ratings. Higher pressures are available, please contact factory.

## THREAD ENDS - MALE • FITTINGS - SCHED. 40 CARBON STEEL • HOSE & BRAID - SERIES 300 STAINLESS STEEL

| PIPE SIZE     | MODEL #  | MOVEMENT | END TO END | LENGTH  | PSI SINGLE BRAID | †PSI DOUBLE BRAID | MAX STEAM PRESS. | *SPRING FORCE LBS. | WEIGHT LBS. |
|---------------|----------|----------|------------|---------|------------------|-------------------|------------------|--------------------|-------------|
| 1/2" (15mm)   | MLT30050 | ±1.5"    | 12"        | 10-1/4" | 1075             | 1720              | 300              | 45                 | 3           |
|               | MLT80050 | ±4"      | 15"        | 15-5/8" |                  |                   |                  |                    | 5.5         |
| 3/4" (20mm)   | MLT30075 | ±1.5"    | 12-1/4"    | 10-3/4" | 792              | 1267              | 300              | 47                 | 3           |
|               | MLT80075 | ±4"      | 15-1/4"    | 17-1/2" |                  |                   |                  |                    | 5.5         |
| 1" (25mm)     | MLT30100 | ±1.5"    | 12"        | 12"     | 571              | 914               | 300              | 53                 | 5           |
|               | MLT80100 | ±4"      | 16"        | 18-5/8" |                  |                   |                  |                    | 8           |
| 1-1/4" (30mm) | MLT30125 | ±1.5"    | 13-1/2"    | 13-3/8" | 531              | 850               | 300              | 66                 | 7           |
|               | MLT80125 | ±4"      | 16-3/4"    | 20"     |                  |                   |                  |                    | 10          |
| 1-1/2" (40mm) | MLT30150 | ±1.5"    | 15"        | 14-3/4" | 472              | 755               | 300              | 70                 | 10.5        |
|               | MLT80150 | ±4"      | 17-1/2"    | 21-1/4" |                  |                   |                  |                    | 14.5        |
| 2" (50mm)     | MLT30200 | ±1.5"    | 18"        | 17-3/8" | 500              | 750               | 300              | 78                 | 15          |
|               | MLT80200 | ±4"      | 20"        | 24-1/2" |                  |                   |                  |                    | 18          |
| 2-1/2" (65mm) | MLT30250 | ±1.5"    | 21"        | 21"     | 387              | 619               | 300              | 83                 | 23          |
|               | MLT80250 | ±4"      | 21-1/2"    | 28-1/4" |                  |                   |                  |                    | 29          |
| 3" (80mm)     | MLT30300 | ±1.5"    | 26"        | 23-3/8" | 288              | 431               | 216              | 90                 | 39          |
|               | MLT80300 | ±4"      | 26"        | 30"     |                  |                   |                  |                    | 43          |
| 4" (100mm)    | MLT30400 | ±1.5"    | 32"        | 28"     | 232              | 371               | 186              | 120                | 55          |
|               | MLT80400 | ±4"      | 32"        | 35-3/8" |                  |                   |                  |                    | 59          |

## 150# FLANGED ENDS • FITTINGS - SCHED. 40 CARBON STEEL • HOSE & BRAID - SERIES 300 STAINLESS STEEL

| PIPE SIZE      | MODEL #  | MOVEMENT | END TO END | LENGTH  | PSI SINGLE BRAID | †PSI DOUBLE BRAID | MAX STEAM PRESS. | *SPRING FORCE LBS. | WEIGHT LBS. |
|----------------|----------|----------|------------|---------|------------------|-------------------|------------------|--------------------|-------------|
| 2" (50mm)      | MLF30200 | ±1.5"    | 12-1/2"    | 17-3/8" | 500              | 750               | 300              | 78                 | 21          |
|                | MLF80200 | ±4"      | 14-1/2"    | 24-1/2" |                  |                   |                  |                    | 24          |
| 2-1/2" (65mm)  | MLF30250 | ±1.5"    | 15-1/2"    | 21"     | 387              | 619               | 300              | 83                 | 30          |
|                | MLF80250 | ±4"      | 16"        | 28-1/4" |                  |                   |                  |                    | 36          |
| 3" (80mm)      | MLF30300 | ±1.5"    | 18-1/2"    | 23-3/8" | 288              | 431               | 216              | 90                 | 46          |
|                | MLF80300 | ±4"      | 18-1/2"    | 30"     |                  |                   |                  |                    | 50          |
| 4" (100mm)     | MLF30400 | ±1.5"    | 24-1/2"    | 28"     | 232              | 371               | 183              | 120                | 63          |
|                | MLF80400 | ±4"      | 24-1/2"    | 35-3/8" |                  |                   |                  |                    | 69          |
| 5" (125mm)     | MLF30500 | ±1.5"    | 30-1/2"    | 32-1/4" | 191              | 306               | 153              | 186                | 91          |
|                | MLF80500 | ±4"      | 30-1/2"    | 40-1/4" |                  |                   |                  |                    | 101         |
| 6" (150mm)     | MLF30600 | ±1.5"    | 36-1/2"    | 36-3/4" | 165              | 264               | 132              | 202                | 148         |
|                | MLF80600 | ±4"      | 36-1/2"    | 45-3/8" |                  |                   |                  |                    | 163         |
| 8" (200mm)     | MLF30800 | ±1.5"    | 48-1/2"    | 44-1/2" | 212              | 230               | 115              | 260                | 287         |
|                | MLF80800 | ±4"      | 48-1/2"    | 53-1/2" |                  |                   |                  |                    | 309         |
| 10" (250mm)    | MLF31000 | ±1.5"    | 60-1/2"    | 53-1/4" | 175              | 200               | 100              | 283                | 453         |
|                | MLF81000 | ±4"      | 60-1/2"    | 63-1/4" |                  |                   |                  |                    | 484         |
| 12" (300mm)    | MLF31200 | ±1.5"    | 72-1/2"    | 61-3/4" | 160              | 188               | 94               | 390                | 636         |
|                | MLF81200 | ±4"      | 72-1/2"    | 72-3/4" |                  |                   |                  |                    | 666         |
| 14" (355mm)    | MLF31400 | ±1.5"    | 84-1/2"    | 71"     | 110              | 125               | 63               | 706                | 636         |
|                | MLF81400 | ±4"      | 84-1/2"    | 80-1/2" |                  |                   |                  |                    | 666         |
| 16" ** (400mm) | MLF31600 | ±1.5"    | 96-1/2"    | 78-1/2" | 110              | 170               | 85               | 900                | 636         |
|                | MLF81600 | ±4"      | 96-1/2"    | 91-1/2" |                  |                   |                  |                    | 666         |
| 18" ** (455mm) | MLF31800 | ±1.5"    | 108-1/2"   | 86-1/2" | 85               | 150               | 75               | 1000               | 636         |
|                | MLF81800 | ±4"      | 108-1/2"   | 100"    |                  |                   |                  |                    | 666         |

† When ordering a Metraloop with double-braid, please include the letter "D" at the end of the Model #. Example: MLW30200D

\* Spring Force: These values reflect the total force required to move the Metraloop its full rated movement for 150 P.S.I. at 70° F.

For higher pressures please contact Metraflex.

# METRALOOP SELECTION CHART

## WELD ENDS • FITTINGS - SCHED. 40 CARBON STEEL • HOSE & BRAID - SERIES 300 STAINLESS STEEL

| PIPE SIZE     | MODEL #  | MOVEMENT | END TO END | LENGTH  | PSI SINGLE BRAID | †PSI DOUBLE BRAID | MAX STEAM PRESS. | *SPRING FORCE LBS. | WEIGHT LBS. |
|---------------|----------|----------|------------|---------|------------------|-------------------|------------------|--------------------|-------------|
| 1/2" (15mm)   | MLW30050 | ±1.5"    | 6"         | 10-1/4" | 1075             | 1720              | 300              | 45                 | 2.5         |
|               | MLW80050 | ±4"      | 9"         | 15-5/8" |                  |                   |                  |                    | 5           |
| 3/4" (20mm)   | MLW30075 | ±1.5"    | 5-1/4"     | 10-3/4" | 792              | 1267              | 300              | 47                 | 2.5         |
|               | MLW80075 | ±4"      | 9-1/4"     | 17-1/2" |                  |                   |                  |                    | 5           |
| 1" (25mm)     | MLW30100 | ±1.5"    | 6"         | 12"     | 571              | 914               | 300              | 53                 | 4           |
|               | MLW80100 | ±4"      | 10"        | 18-5/8" |                  |                   |                  |                    | 7           |
| 1-1/4" (30mm) | MLW30125 | ±1.5"    | 7-1/2"     | 13-3/8" | 531              | 850               | 300              | 66                 | 6           |
|               | MLW80125 | ±4"      | 10-3/4"    | 20"     |                  |                   |                  |                    | 9           |
| 1-1/2" (40mm) | MLW30150 | ±1.5"    | 9"         | 14-3/4" | 472              | 755               | 300              | 70                 | 9           |
|               | MLW80150 | ±4"      | 11-1/2"    | 21-1/4" |                  |                   |                  |                    | 13          |
| 2" (50mm)     | MLW30200 | ±1.5"    | 12"        | 17-3/8" | 500              | 750               | 300              | 78                 | 13          |
|               | MLW80200 | ±4"      | 14"        | 24-1/2" |                  |                   |                  |                    | 16          |
| 2-1/2" (65mm) | MLW30250 | ±1.5"    | 15"        | 21"     | 387              | 619               | 300              | 83                 | 20          |
|               | MLW80250 | ±4"      | 15-1/2"    | 28-1/4" |                  |                   |                  |                    | 26          |
| 3" (80mm)     | MLW30300 | ±1.5"    | 18"        | 23-3/8" | 288              | 431               | 216              | 90                 | 35          |
|               | MLW80300 | ±4"      | 18"        | 30"     |                  |                   |                  |                    | 39          |
| 4" (100mm)    | MLW30400 | ±1.5"    | 24"        | 28"     | 232              | 371               | 186              | 120                | 48          |
|               | MLW80400 | ±4"      | 24"        | 35-3/8" |                  |                   |                  |                    | 54          |
| 5" (125mm)    | MLW30500 | ±1.5"    | 30"        | 32-1/4" | 191              | 306               | 153              | 186                | 81          |
|               | MLW80500 | ±4"      | 30"        | 40-1/4" |                  |                   |                  |                    | 91          |
| 6" (150mm)    | MLW30600 | ±1.5"    | 36"        | 36-3/4" | 165              | 264               | 132              | 202                | 125         |
|               | MLW80600 | ±4"      | 36"        | 45-3/8" |                  |                   |                  |                    | 140         |
| 8" (200mm)    | MLW30800 | ±1.5"    | 48"        | 44-1/2" | 212              | 230               | 115              | 260                | 245         |
|               | MLW80800 | ±4"      | 48"        | 53-1/2" |                  |                   |                  |                    | 267         |
| 10" (250mm)   | MLW31000 | ±1.5"    | 60"        | 53-1/4" | 175              | 200               | 100              | 383                | 403         |
|               | MLW81000 | ±4"      | 60"        | 63-1/4" |                  |                   |                  |                    | 434         |
| 12" (300mm)   | MLW31200 | ±1.5"    | 72"        | 61-3/4" | 160              | 188               | 94               | 390                | 556         |
|               | MLW81200 | ±4"      | 72"        | 72-3/4" |                  |                   |                  |                    | 586         |

Pressure ratings reflect standard ratings. Higher pressures are available, please contact factory.

## GROOVED ENDS • FITTINGS - SCHED. 40 CARBON STEEL • HOSE & BRAID - SERIES 300 STAINLESS STEEL

| PIPE SIZE     | MODEL #  | MOVEMENT | FACE TO FACE | LENGTH  | PSI SINGLE BRAID | †PSI DOUBLE BRAID | *SPRING FORCE LBS. | WEIGHT LBS. |
|---------------|----------|----------|--------------|---------|------------------|-------------------|--------------------|-------------|
| 2" (50mm)     | MLG30200 | ±1.5"    | 18"          | 17-3/8" | 500              | 750               | 78                 | 15          |
|               | MLG80200 | ±4"      | 20"          | 24-1/2" |                  |                   |                    | 18          |
| 2-1/2" (65mm) | MLG30250 | ±1.5"    | 21"          | 21"     | 387              | 619               | 83                 | 23          |
|               | MLG80250 | ±4"      | 21-1/2"      | 28-1/4" |                  |                   |                    | 29          |
| 3" (80mm)     | MLG30300 | ±1.5"    | 24"          | 23-3/8" | 288              | 431               | 90                 | 39          |
|               | MLG80300 | ±4"      | 24"          | 30"     |                  |                   |                    | 43          |
| 4" (100mm)    | MLG30400 | ±1.5"    | 30"          | 28"     | 232              | 371               | 120                | 54          |
|               | MLG80400 | ±4"      | 30"          | 35-3/8" |                  |                   |                    | 60          |
| 5" (125mm)    | MLG30500 | ±1.5"    | 36"          | 32-1/4" | 191              | 306               | 186                | 89          |
|               | MLG80500 | ±4"      | 36"          | 40-1/4" |                  |                   |                    | 99          |
| 6" (150mm)    | MLG30600 | ±1.5"    | 42"          | 36-3/4" | 165              | 264               | 202                | 135         |
|               | MLG80600 | ±4"      | 42"          | 45-3/8" |                  |                   |                    | 150         |
| 8" (200mm)    | MLG30800 | ±1.5"    | 56"          | 44-1/2" | 212              | 230               | 260                | 264         |
|               | MLG80800 | ±4"      | 56"          | 53-1/2" |                  |                   |                    | 286         |
| 10" (250mm)   | MLG31000 | ±1.5"    | 68"          | 53-1/4" | 175              | 200               | 283                | 430         |
|               | MLG81000 | ±4"      | 68"          | 63-1/4" |                  |                   |                    | 461         |
| 12" (300mm)   | MLG31200 | ±1.5"    | 80"          | 61-3/4" | 160              | 188               | 390                | 592         |
|               | MLG81200 | ±4"      | 80"          | 72-3/4" |                  |                   |                    | 622         |

† When ordering a Metraloop with double-braid, please include the letter "D" at the end of the Model #. Example: MLW30200D  
 \* Spring Force: These values reflect the total force required to move the Metraloop its full rated movement for 150 P.S.I. at 70° F.  
 For higher pressures please contact Metraflex.

### METRALOOP OPTIONS

The sizes, pressures and movements shown reflect our standard MetraLoops. Higher pressure, greater movements and special materials, such as all stainless steel construction are available. Please contact your local Metraflex representative or the factory 800-621-4347 for more information.

Metraflex reserves the right to change product specifications, designs and standard equipment without notice and without incurring obligation.

For safe working pressures above 70°F, multiply the pressures shown at 70°F by the correction factor for the required temperature

| TEMPERATURE ° F | CORRECTION FACTOR |                 |
|-----------------|-------------------|-----------------|
|                 | BRONZE            | STAINLESS STEEL |
| 70°             | 1.0               | 1.0             |
| 200°            | .89               | .92             |
| 300°            | .83               | .86             |
| 400°            | .78               | .82             |
| 500°            | —                 | .77             |
| 600°            | —                 | .73             |

# INSTALLATION/GUIDING CONSIDERATIONS

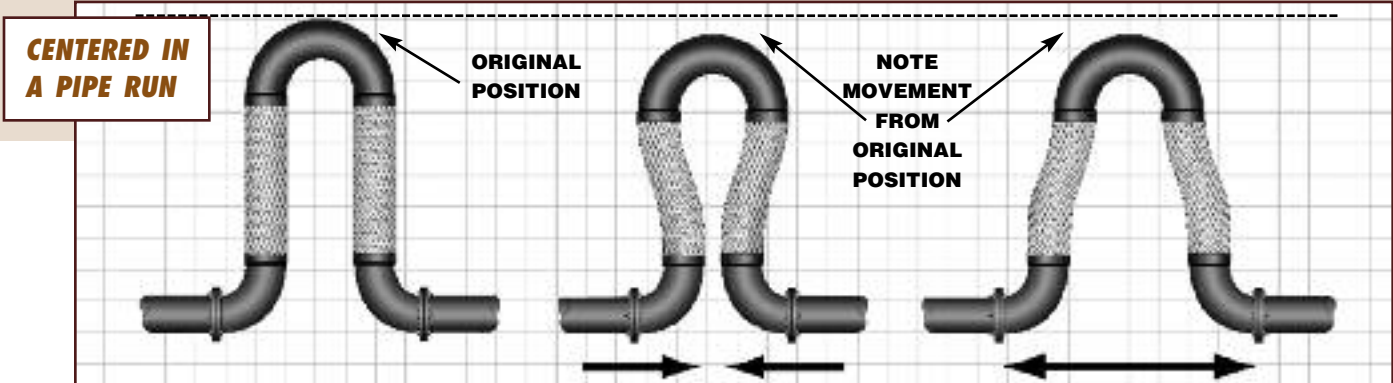

**Centered in a pipe run:** when the loop is installed in the middle of a pipe run, the loop will flex symmetrically and the 180 will move toward and away from the pipe. The 180 support should be designed with enough slack to allow the 180 to move 10% of the loops designed movement. For example a loop designed for  $\pm 4$  inches of axial movement will see the 180 return bend move 4 tenths (0.4") of an inch.

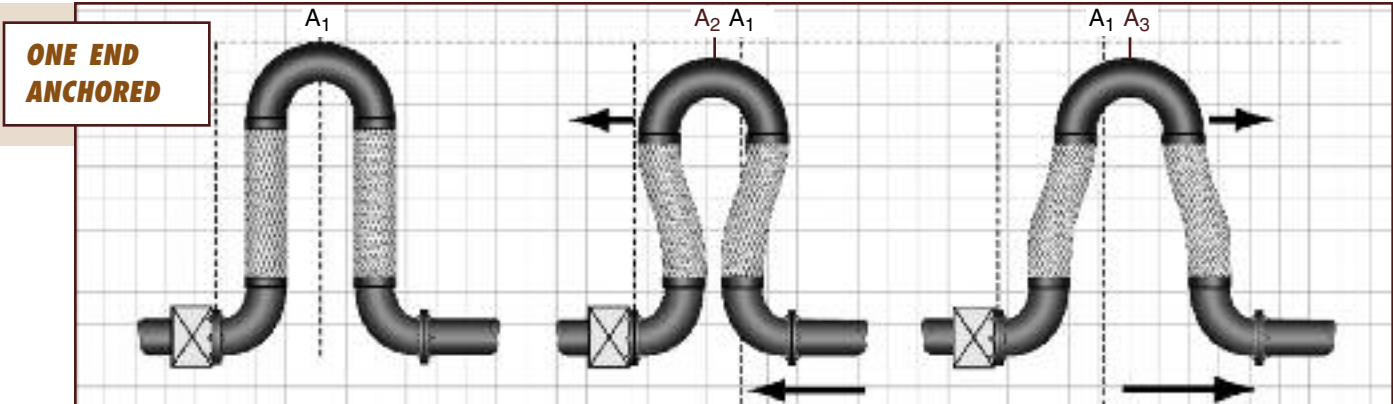

**One end anchored:** When installed at or near an anchor the 180 will have a lateral component to its movement, in addition to the movement shown above ("Centered in a pipe run"). The lateral movement will be 50% of the thermal expansion or contraction and it will be in the same direction as the pipe movement. Again a sufficiently slack hanger rod or slide support is all that is required.

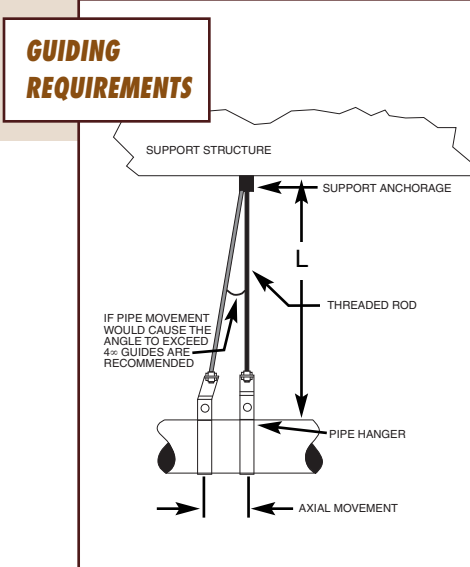

| MINIMUM 'L' REQUIRED TO ELIMINATE GUIDES |                |
|--|----------------|
| AXIAL MOVEMENT                           | ROD 'L' LENGTH |
| 1"                                       | 14"            |
| 2"                                       | 28"            |
| 4"                                       | 57"            |
| 6"                                       | 85"            |

**Guiding Requirements:** Thermal Movement - Being the most flexible component of your piping system, the MetraLoop is the path of least resistance. And unlike other expansion joint devices, bellows, hard pipe loops, ball or slip type joints, the loop will absorb any thermal expansion before your pipe develops a tendency to bow out of position. As long as the loops design parameters are not exceeded the loop does not need guides.

However, the Mechanical Contractors Association of America "Guidelines for Quality Piping Installations" section 3 Pipe Hangers and Supports, suggests to ensure movement is directed as expected and if your piping is supported on pipe hangers that will swing more than 4 degrees from vertical when the pipe moves it is recommended that a pipe guide be installed anywhere within 15 pipe diameters on each side of the MetraLoop. Loops anchored on one side need only one guide on the traveling side.

Guiding Requirements - Seismic Movement - When spanning a buildings seismic expansion joint, guides are not required. See page 11.



# APPLICATIONS

## NESTED METRALOOPS:

Nested MetraLoops can be used in parallel pipe runs to keep all the expansion or seismic devices at one location. MetraLoops can be nested in any sequence, large inside of smaller diameters or small inside of large and any number of pipes can be made in a nest.

## C.S.A./A.G.A. GAS LOOPS:

Selected sizes, designs and materials of construction for the MetraLoops have been tested and certified by C.S.A./A.G.A. for use on gas pipe lines. These MetraLoops are being used primarily in commercial and industrial facilities located in seismic zones to minimize the possibility of gas line ruptures. Fires caused by broken gas lines are the major cause of damage after earthquakes.

## MEDICAL LOOPS:

Many healthcare facilities, especially in seismically rated areas, require flexibility in all piping systems. Optional cleaning, capping, and certifying, for all medical gas applications including medical oxygen, vacuum, and compressed air. For sealed systems, such as oxygen service, loops are supplied without drain/air release plugs. The Metraloop is accepted by the California Office of Statewide Health Planning and Development (OSHPD) for use in hospitals.

## SPRINKLER SEISMIC LOOP:

Historically, seismic flexibility in fire sprinkler lines has been accomplished using a complex series of couplings. The UL listed Fireloop is a pre-tested factory warranted seismic expansion joint that is compact and can be oriented in any direction. The Fireloop meets NFPA-13 standards A-6-4.1 & 4.2 for seismic joints in fire sprinkler systems. See catalog Fireloop or [www.metroflex.com](http://www.metroflex.com) for complete information.

## MULTIPLE PIPE RUNS

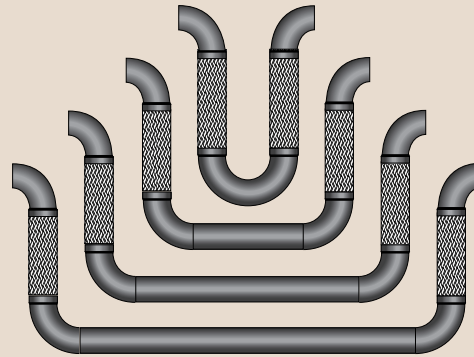

## NATURAL GAS LINES

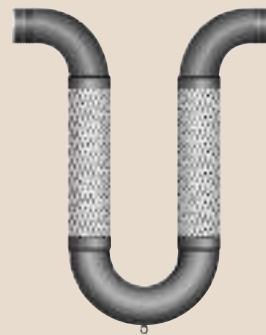

## MEDICAL GASES

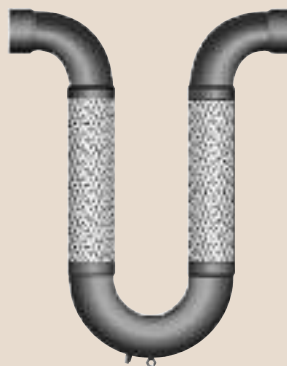

## FIRE SPRINKLERS

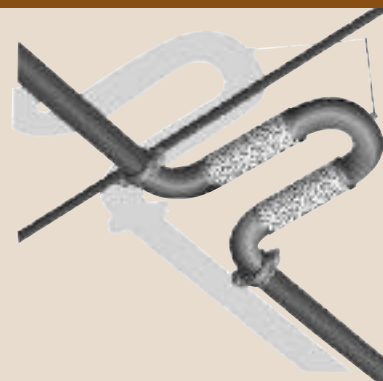

# APPLICATIONS

## ONE LOOP FOR TWO RUNS

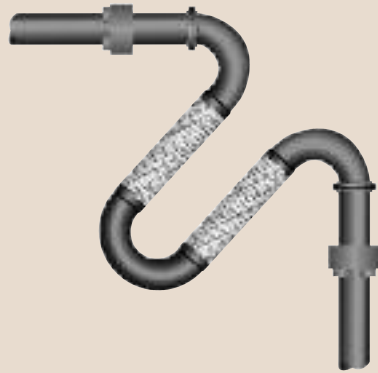

## HI VELOCITY SYSTEMS

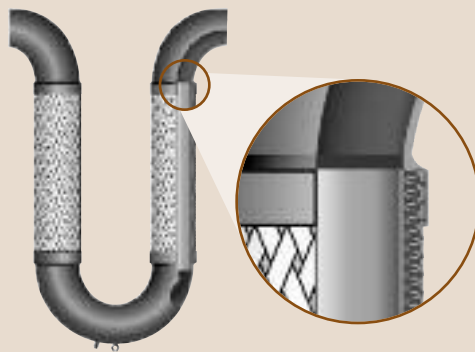

## CONTAINMENT OR STEAM JACKETED PIPING

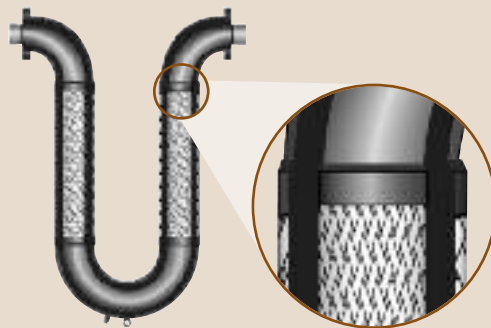

## SEWAGE SYSTEMS

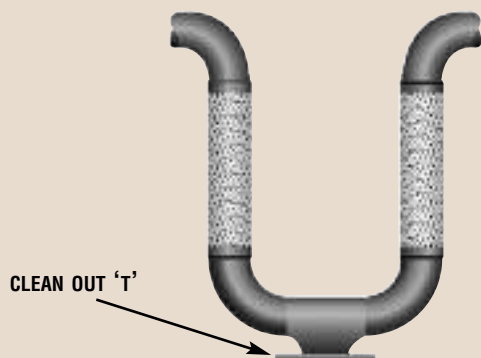

## CORNER LOOPS:

One Metraloop simultaneously absorbs the thermal expansion of two pipe runs. Space-saving inside corner Metraloop eliminates the need for an anchor at the corner. Support must be provided to prevent Metraloop from drooping or torquing pipe and must allow for sufficient movement.

## LINED METRALOOPS:

Liners are used when flow velocity exceeds 25 ft/sec. through the hose assembly or when the fluid is erosive.

A liner will reduce turbulence and pressure drop if this is critical to the application. Spiral wound interlocked flexible hose is commonly used for the liner.

## CONTAINMENT LOOPS OR STEAM JACKETED PIPING:

Containment MetraLoops for hazardous media can be built of almost any compatible material. A large inspection port in the return bend is a common option. Containment loops can be designed for thermal expansion, seismic, tank settling, nozzle loading requirements, etc. . .

Steam jacketed loops are used to heat or reheat media and at the same time absorb or compensate for thermal movement. Steam connections can be made anywhere except in the flexible legs.

## SEWAGE (POOP) LOOP:

Lined to minimize sediment collection, these loops are designed with a clean out "T" to facilitate servicing and to comply with most code requirements. The loops are installed in the sewage lines as they exit a building foundation to allow for building settlement. They are also used in and outside the building to accommodate seismic movement.

# APPLICATIONS

## NOZZLE LOAD LOOPS:

Pipe stress and nozzle loading due to settlement can be eliminated. Use Metraloops on storage tanks, building separations, or any large equipment where stress relief is required. One assembly may be used to simultaneously absorb seismic, thermal, and settlement movements.

## ROOF LOOPS:

Due to their large forces, most rooftop thermal expansion devices require penetration of the roof to anchor and support the piping. Metraloops permit the use of wooden sleepers or other similar supports that maintain the integrity of the roofing material.

## BURIED LOOPS:

All of the benefits of using The Metraloop for above ground systems can be applied to buried systems as well. The Metraloop will virtually eliminate all anchor loads from the system reducing anchor plate and thrust block requirements. The Metraloop will take up 75% less space than conventional hard pipe loops lowering excavation cost, and can be incorporated into the design of conduit systems. The Metraloop will provide an additional benefit of protecting the piping system and equipment from the effects of building settling and soil shifting.

## TRENCH BOX SYSTEM:

Requiring a fraction of the space of hard pipe loops, excavation and dirt disposal are minimized using the Metraloop. Rack supports using pipe rollers or slide supports are ideal for the pipe runs.

### STORAGE TANKS

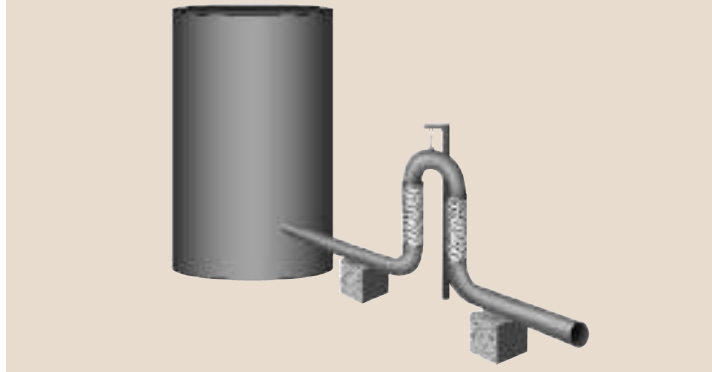

### ROOF TOP PIPING

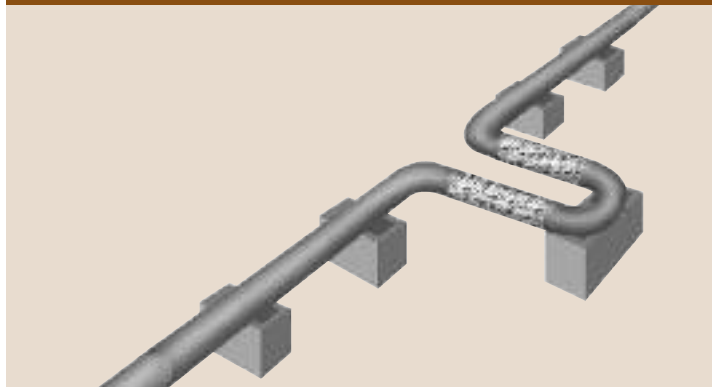

### UNDERGROUND PIPING

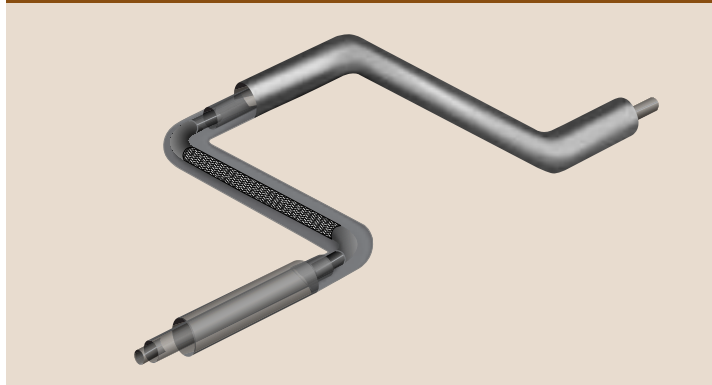

### TRENCH BOX SYSTEMS

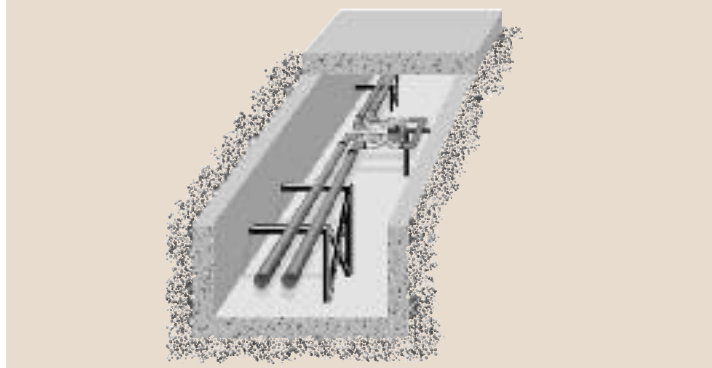

# THERMAL EXPANSION APPLICATIONS

Flexible stainless steel hose and braid is an excellent product for absorbing lateral offset and angular movement. It is not well suited for axial compression, or torque. Under axial compression the braid is relaxed which lowers the pressure rating, and torque introduces complex stresses that quickly fatigue the hose.

With the above in mind, if hose and braid is to be used as the stress relieving, movement compensating component of a piping system it must be installed in a configuration that minimizes the axial compression of the hose and braid.

## METRALOOP

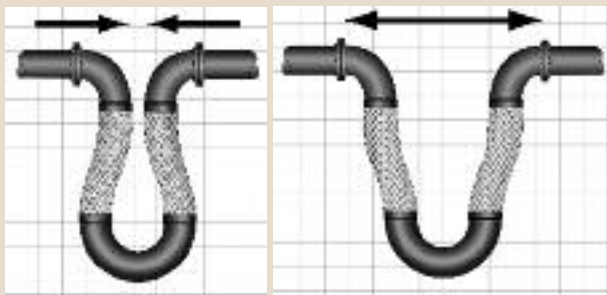

EXPANSION

CONTRACTION

## APPLICATIONS

Metraloops can be used in any thermal expansion application. Virtually any amount of movement is available.

Steel Pipe - Metraloops are available in flanged, weld, or grooved or any combination to suit the system requirements.

Stainless Steel Pipe - For corrosive or seawater applications, all stainless steel construction is available.

Copper Pipe - The column strength of small diameter copper pipe is very low. Bellows type copper compensators require many pipe guides to maintain column strength. Metraloops exert no pressure thrust on the pipe reducing this requirement.

Plastic Pipe - Typically has much greater coefficients of expansion than either copper or steel and is more brittle. Again, the Metraloop with its low spring rate is ideal.

## DESIGN CONSIDERATIONS

The best configuration to accommodate thermal expansion is the Metraloop. When the loop is installed in a pipe run that is expanding or contracting axially, the flexible legs, being perpendicular to the movement vector, are flexed laterally. As long as the legs are designed with sufficient live length the offset amount never exceeds the elastic limit of the hose and it will flex indefinitely.

In hot and cold water systems, Metraloops may be installed in any orientation relative to the piping and at any location along the pipe run. The pipes expansion or contraction will find it's way to the Metraloop. Due to the loops ability to accommodate large amounts of movement, it should be located in such a way as to limit stress on branch lines.

In steam systems, care must be taken to prevent condensate build up that could be harmful to other components downstream of the loop. For this reason we require steam Metraloops to be oriented horizontally. (See page 3, Illustration #1). Vertical steam risers do not apply. As an additional safety precaution all steam loops are double braided. Please specify service when ordering.

## BENEFITS

The Metraloop is an inexpensive alternative to other methods of designing for thermal expansion such as bellows-type expansion joints, slip-type (packed) expansion joints or hard-pipe loops.

System costs are reduced because the Metraloop exerts only a fraction of the anchor loads of all other type expansion joints. And, due to it's natural flexibility, the Metraloop requires far fewer pipe guides than are required for bellows expansion joints and takes up less space than a hard-pipe loop. (See inside front cover for anchor load and space comparisons.)

Metraloops reduce the entire cost of the system in three ways:

- \* Reduce Anchor Costs - Smaller anchor loads means smaller, less expensive anchors. No expensive thrust blocks or heavy-duty main anchors are required.
- \* Reduce Guiding Costs - Only two pipe guides are required per Metraloop. Compared to the stringent requirements of other expansion joints, this can add up to a considerable savings.
- \* Reduce Construction Material Costs - Metraloops require much less space than hard pipe loops. That means smaller vaults when digging steam trenches, less concrete and less dirt for removal.



**For a video demonstration of the MetraLoop, contact your local Metraflex representative, or call 800-621-4347.**



# SEISMIC APPLICATIONS

## BENEFITS

The Metraloop is a better alternative to other methods of designing for seismic movement such as dual-tied bellows expansion joints, or ball-joints.

System costs are reduced because the Metraloop exerts only a fraction of the anchor loads of a ball-joint or a bellows expansion joint. That means no expensive thrust blocks or heavy-duty anchors are required. (See Inside Front Cover for anchor load comparison)

The extreme flexibility of the Metraloop also makes it ideal as a seismic connector to equipment such as boilers, chillers, and fan-coil units. Metraloops minimize equipment nozzle loading conditions.

## DESIGN CONSIDERATIONS

The randomness of the movement in an earthquake requires that seismic expansion joints be capable of movement in any direction. Of all the six possible directions  $\pm X$ ,  $\pm Y$ ,  $\pm Z$  (Figure 1) the Metraloop is the optimal configuration as compared with other type of flexible hose and braid seismic connectors. By design, flexible hose and braid connectors are limited to angular motion and lateral offset. Axial, compressive, or torsional movement is not possible. By fabricating an assembly with two sections of hose parallel to each other, and allowing the 180° return bend to move freely, the Metraloop minimizes the likelihood of compressive movement.

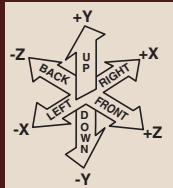

FIGURE 1

For movement in the  $+X$ ,  $-X$  & planes (expansion & contraction), the Metraloop uses hose offset motion to achieve this movement. Also for movement in the  $+Z$ ,  $-Z$  planes (front & back), the Metraloop uses hose offset motion. Movement in the  $+Y$ ,  $-Y$  Plane (up-down), the legs of the Metraloop use hose angular motion for this movement.

Note: The use of assemblies with flexible hose sections oriented at 90° relative to each other can result in axial compression or torque of the hose. This may result in failure or shorter service life of the assembly. A non-structural disadvantage of these types of configurations is the cost and logistics of the necessary offsets in the pipe runs or additional supports required.

## APPLICATIONS

Metraloops can be used in all types of systems including steam, hot or chilled water, medical gas, natural gas (See A.G.A./C.S.A. certified drawing, page 16), fire sprinklers, sewage, chemical, and petroleum products. Special applications requiring lined hose for high velocity, double-braid for high pressures, and all stainless steel construction for media compatibility are available (See pages 7-9 for a few of these special applications).

## SEISMIC INSTALLATION

Figures 2 thru 4 show typical installations of Metraloops for seismic service. These drawings, along with detailed installation instructions for seismic applications can be found on our website and by contacting your local Metraflex representative.

FIGURE 2 - CROSSING A BUILDING SEISMIC JOINT - HORIZONTAL



FIGURE 3 - CROSSING A BUILDING SEISMIC JOINT - VERTICAL

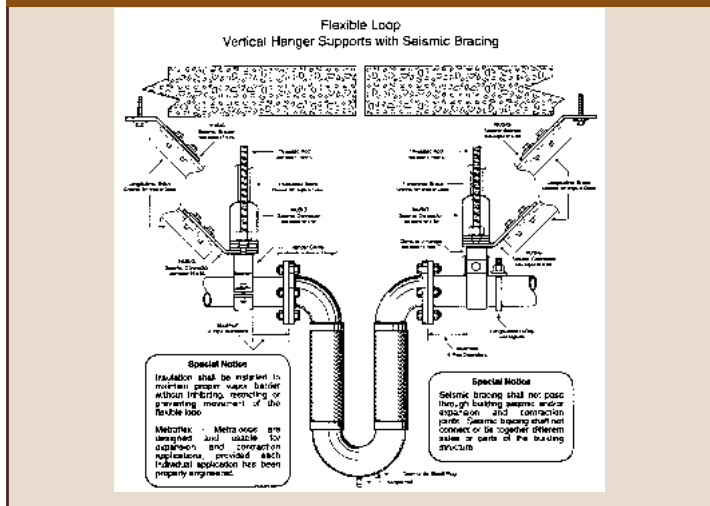
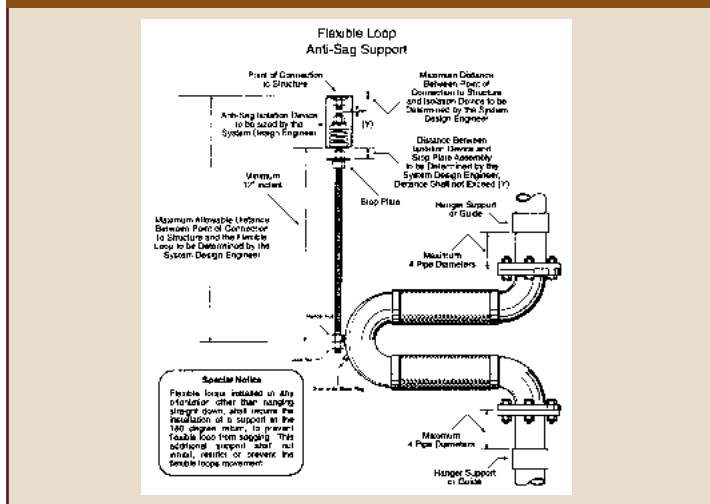

FIGURE 4 - RISER APPLICATION



# SUMMARY OF THE TEST REPORT OF WISS, JANNEY, ELSTNER ASSOCIATES, INC. NORTHBROOK, IL

## METRALOOP CYCLE TESTING



WJE was commissioned to perform cycle testing on 4", 6", and 8" diameter MetraLoops simulating the movement that would be expected in an earthquake. All MetraLoops which were submitted passed the cycle testing.

Description of test procedure and equipment:  
MetraLoops designed for 4 inches of movement in any direction were pressurized and mounted between two carts. The carts moved perpendicular to each other and were set to simultaneously cycle at +4 inches and -4 inches at a rate of 2 cycles per second for 30 cycles. After 30 cycles, none of the MetraLoops showed any signs of stress, damage or fatigue.

## WJE TEST NO. 941166



After the successful completion of the original test, a 4-inch diameter MetraLoop was subjected to progressively larger amplitudes of movement until failure. First for 30 cycles at  $\pm 6$  inches and then  $\pm 8$  inches (100% above design movement). At 100% above design movement, the MetraLoop started to leak.

The full test report and a video of the testing is available upon request, please contact the factory.



# PRESSURE DROP CHARTS

## 1/2" TO 16" DIAMETER METRALOOPS

Because of their compact size MetraLoops have a lower pressure drop than the same movement hard pipe loop. The pressure drops note on these charts are the standard MetraLoops designed for ± 4 inches of movement.

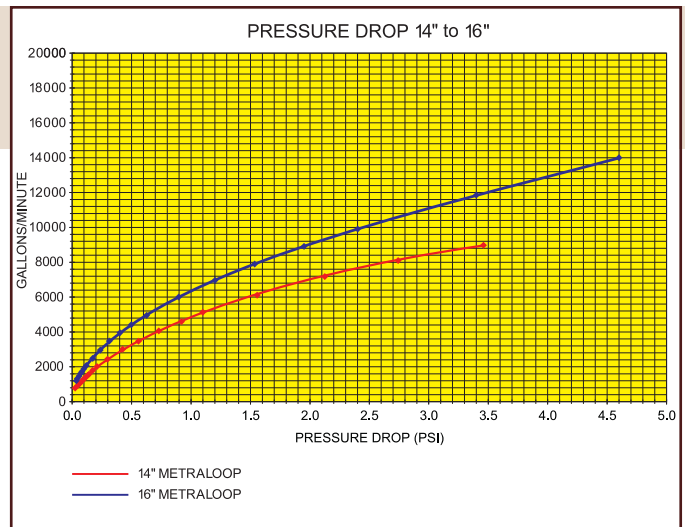
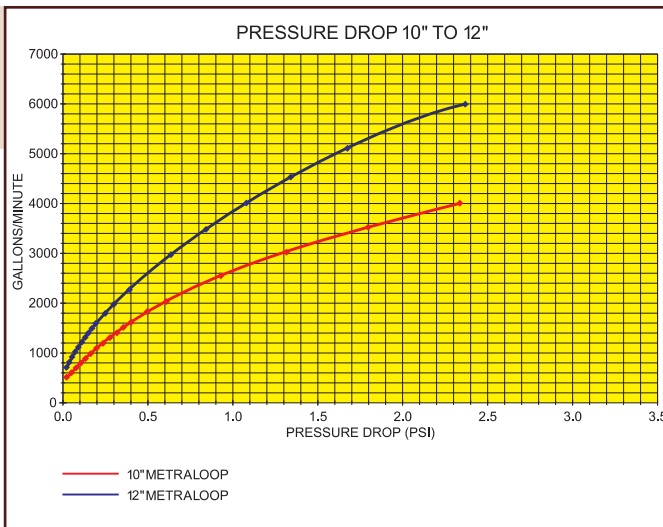
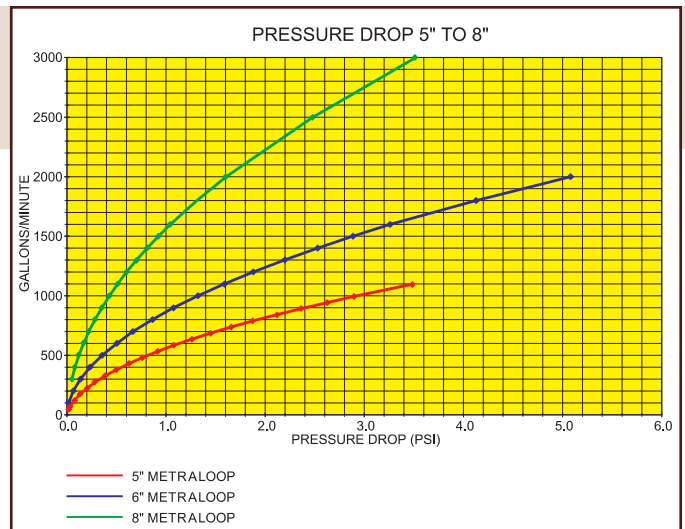
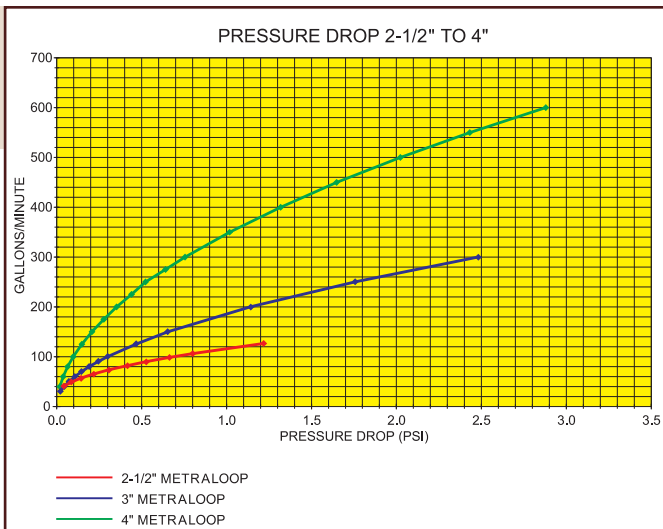
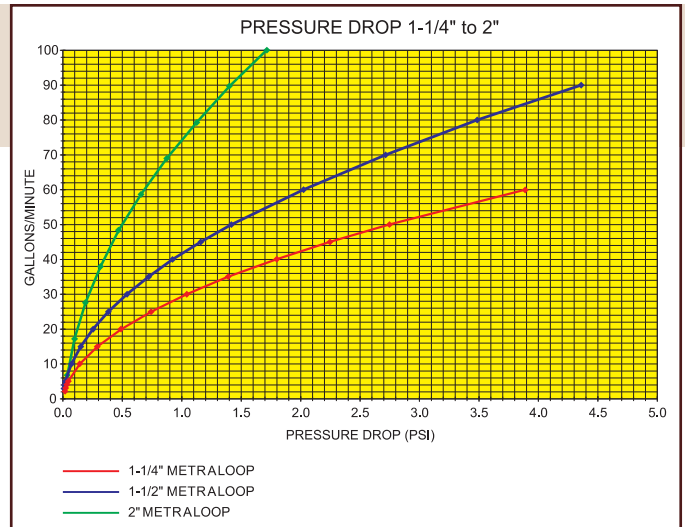
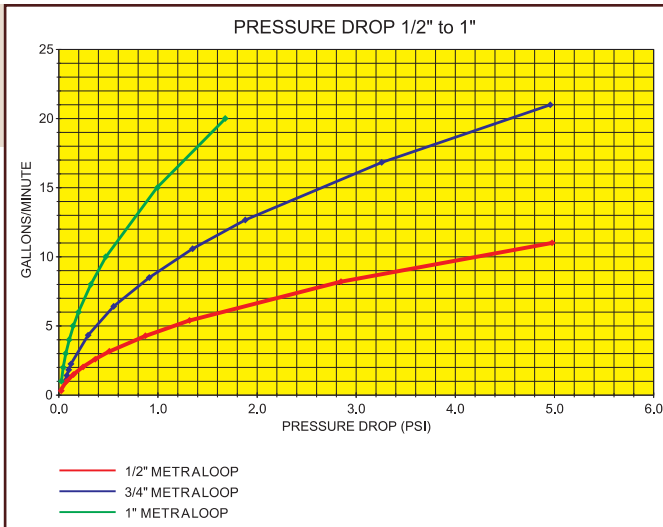

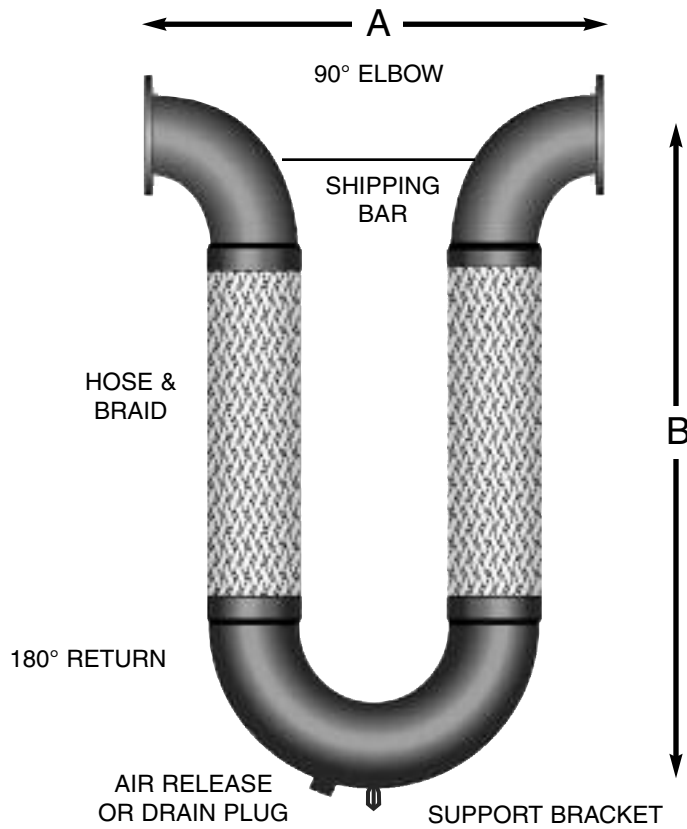
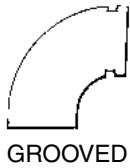
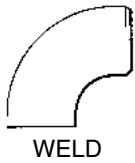
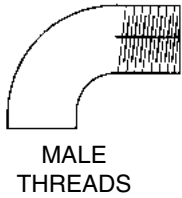
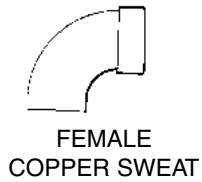

**MATERIALS  
OF  
CONSTRUCTION**

End Fittings \_\_\_\_\_  
 Hose & Braid \_\_\_\_\_  
 90° Elbow \_\_\_\_\_  
 180° Return \_\_\_\_\_

**NOTE:** METRALOOPS 2" AND LARGER INSTALLED IN ANY ORIENTATION OTHER THAN HANGING DOWN MUST HAVE THE 180° RETURN SUPPORTED. (SEE INSTALLATION INSTRUCTIONS.)

| QTY. | SIZE | MODEL # | AXIAL MOVEMENT | A | B | PSI @ 70° F | NOTES |
|------|------|---------|----------------|---|---|-------------|-------|
|      |      |         |                |   |   |             |       |
|      |      |         |                |   |   |             |       |
|      |      |         |                |   |   |             |       |
|      |      |         |                |   |   |             |       |
|      |      |         |                |   |   |             |       |
|      |      |         |                |   |   |             |       |
|      |      |         |                |   |   |             |       |
|      |      |         |                |   |   |             |       |
|      |      |         |                |   |   |             |       |

ALL DIMENSIONS IN INCHES

CUSTOMER \_\_\_\_\_  
 PROJECT \_\_\_\_\_  
 ENGINEER \_\_\_\_\_  
 ARCHITECT \_\_\_\_\_  
 PRO. OR P.O. NO \_\_\_\_\_



DESCRIPTION:

**METRALOOP™**

U.S. PAT# 5,195,784

DRAWN BY:  
**JRR**

DATE:  
**11/02**

DRAWING NO:  
**ML02**



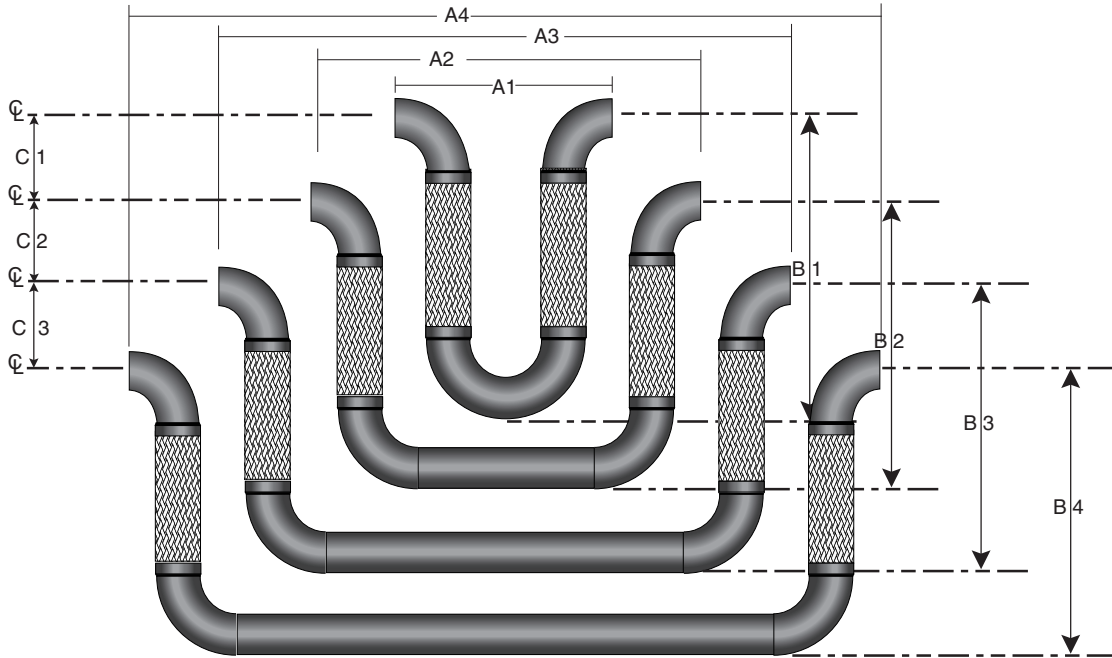

TAG INFO \_\_\_\_\_  
 NEST LOCATION & NOTES \_\_\_\_\_

| LOOP # | PIPE SIZE | END FITTING | MOVEMENT               |                 |                | MAX SERVICE<br>PSI/TEMP | INSUL THICK | DIMENSIONS SUPPLIED BY FACTORY |                                    | DISTANCE BETWEEN PIPE |
|--------|-----------|-------------|------------------------|-----------------|----------------|-------------------------|-------------|--------------------------------|------------------------------------|-----------------------|
|        |           |             | SEISMIC ALL DIRECTIONS | AXIAL           |                |                         |             | A OAL                          | B CENTER OF PIPE TO BOTTOM OF LOOP |                       |
|        |           |             |                        | COMPR-<br>SSION | EXTEN-<br>SION |                         |             |                                |                                    |                       |
| 1      |           |             |                        |                 |                |                         |             | A <sub>1</sub>                 | B <sub>1</sub>                     |                       |
| 2      |           |             |                        |                 |                |                         |             | A <sub>2</sub>                 | B <sub>2</sub>                     | C <sub>1</sub>        |
| 3      |           |             |                        |                 |                |                         |             | A <sub>3</sub>                 | B <sub>3</sub>                     | C <sub>2</sub>        |
| 4      |           |             |                        |                 |                |                         |             | A <sub>4</sub>                 | B <sub>4</sub>                     | C <sub>3</sub>        |

MISC. LOOP NOTES: There is no limit to the number of loops in a nest. Any sequence of pipe diameters is acceptable. Loops do not have to "hang down" as illustrated; up, down, sideways is acceptable.

| PIPE GUIDES |      |      |         |       |
|-------------|------|------|---------|-------|
| FOR LOOP#   | SIZE | QTY. | MODEL # | NOTES |
| 1           |      |      |         |       |
| 2           |      |      |         |       |
| 3           |      |      |         |       |
| 4           |      |      |         |       |

CUSTOMER \_\_\_\_\_  
 PROJECT \_\_\_\_\_  
 ENGINEER \_\_\_\_\_  
 ARCHITECT \_\_\_\_\_  
 PRO. OR P.O. NO \_\_\_\_\_



DESCRIPTION:  
**METRALOOP NEST**  
 U.S. PAT# 5,195,784

|                         |                       |                             |
|-------------------------|-----------------------|-----------------------------|
| DRAWN BY:<br><b>JRR</b> | DATE:<br><b>11/02</b> | DRAWING NO:<br><b>MLNST</b> |
|-------------------------|-----------------------|-----------------------------|

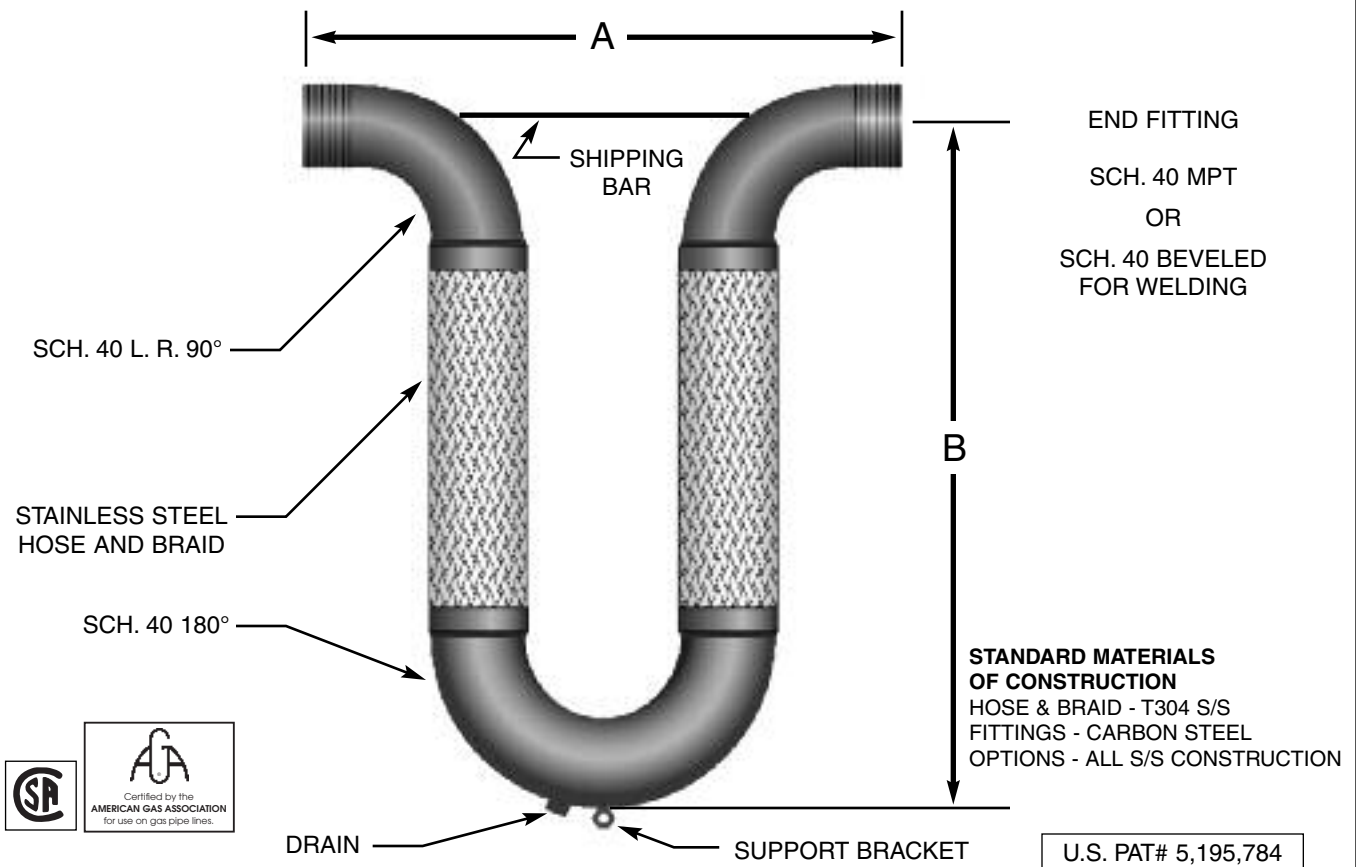

| Qty. | Size   | A<br>Weld / Thread | B   | Movement*                    |       | Max.<br>Working<br>Pressure<br>(psi) @ 70° F | Support<br>Bracket | Notes |
|------|--------|--------------------|-----|------------------------------|-------|--|--------------------|-------|
|      |        |                    |     | Seismic<br>All<br>Directions | Axial |  |                    |       |
|      | 1/2"   | 15"                | 18" | 4"                           | +/-4" | 150  | 1/2"               |       |
|      | 3/4"   | 15-1/4"            | 20" | 4"                           | +/-4" | 150  | 1/2"               |       |
|      | 1"     | 16"                | 22" | 4"                           | +/-4" | 150  | 5/8"               |       |
|      | 1-1/4" | 16-3/4"            | 22" | 4"                           | +/-4" | 150  | 5/8"               |       |
|      | 1-1/2" | 17-1/2"            | 23" | 4"                           | +/-4" | 150  | 5/8"               |       |
|      | 2"     | 20"                | 25" | 4"                           | +/-4" | 150  | 5/8"               |       |
|      | 2-1/2" | 21-1/2"            | 26" | 4"                           | +/-4" | 150  | 5/8"               |       |
|      | 3"     | 26"                | 29" | 4"                           | +/-4" | 150  | 5/8"               |       |
|      | 4"     | 32"                | 37" | 4"                           | +/-4" | 150  | 5/8"               |       |

\*MOVEMENT IS FROM 'A' DIMENSION. DO NOT TORQUE. CONTACT FACTORY FOR INSTALLATION INSTRUCTIONS.

CUSTOMER \_\_\_\_\_  
 PROJECT \_\_\_\_\_  
 ENGINEER \_\_\_\_\_  
 ARCHITECT \_\_\_\_\_  
 PRO. OR P.O. NO \_\_\_\_\_



DESCRIPTION: **METRALOOP®**  
**EXPANSION JOINT / SEISMIC**  
**CONNECTOR FOR GAS SERVICE**

|                         |                         |                                |
|-------------------------|-------------------------|--------------------------------|
| DRAWN BY:<br><b>JRR</b> | DATE:<br><b>8/25/93</b> | DRAWING NO:<br><b>LOOP-GAS</b> |
|-------------------------|-------------------------|--------------------------------|

# TERMS AND CONDITIONS

1. All quotations are subject to approval, acceptance and correction at the home office. Any errors in quotations resulting in orders will be corrected and submitted to the customer for their acceptance or refusal.

No prices may be made up from information other than that shown in the tables.

2. All prices are F.O.B. factory, Chicago, Illinois, and are quoted exclusive of any taxes.

Shipments boxed for trans-ocean export, add 10% to total trade prices.

Terms: Net 30 days from date of invoice.

3. Cancellation or alteration of an order or return of any product by Buyer may not be made without advance written consent of manufacturer and shall be subject to a cancellation charge. Custom products are not returnable.

A 30% minimum restocking charge shall be placed on any returned goods, or a \$25.00 charge (whichever is greater).

4. We will not be responsible for delays in shipping due to conditions beyond our control such as strikes, fires, or accidents.

5. Any claims for shortages or damaged products must be made in writing within 10 days after receipt of shipment.

6. Prices subject to change without notice.

## ***Design and Dimensional Specifications***

The products illustrated reflect the design characteristics at time of printing.

Metraflex reserves the right to change dimensions, material, or methods of construction without notice. Please contact the factory for certified prints (exact dimensions) when necessary.

## ***Limited Warranty***

All products are warranted to be free of defects in material and workmanship for a period of one year from the date of shipment, subject to the limitations below.

If the purchaser believes a product is defective the purchaser shall: (a) Notify the manufacturer, state the alleged defect and request permission to return the product. (b) If permission is given, return the product with transportation prepaid. If the product is accepted for return and found to be defective, the manufacturer will, at its discretion, either repair or replace the product, F.O.B. factory, within 60 days of receipt, or refund the purchase price. Other than to repair, replace or refund as described above, purchaser agrees that manufacturer shall not be liable for any loss, costs, expenses or damages of any kind arising out of the product,

its uses, installation or replacement, labeling, instructions information or technical data of any kind, description of product or use, samples or model, warnings or lack of any of the foregoing. NO OTHER WARRANTIES, WRITTEN OR ORAL, EXPRESS OR IMPLIED, INCLUDING THE WARRANTIES OF FITNESS FOR A PARTICULAR PURPOSE AND MERCHANTABILITY, ARE MADE OR AUTHORIZED. NO AFFIRMATION OF FACT, PROMISE, DESCRIPTION OF PRODUCT OF USE OR SAMPLE OR MODEL SHALL CREATE ANY WARRANTY FROM MANUFACTURER, UNLESS SIGNED BY THE PRESIDENT OF MANUFACTURING. These products are not manufactured, sold or intended for personal, family or household purposes.

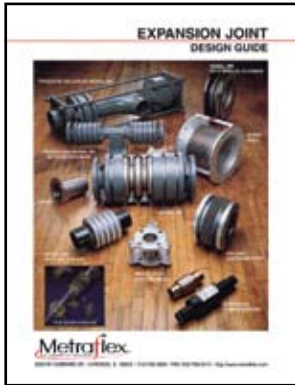

• METAL BELLOWS EXPANSION JOINTS

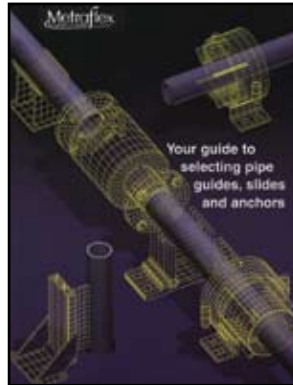

• GUIDES, SLIDES AND ANCHORS

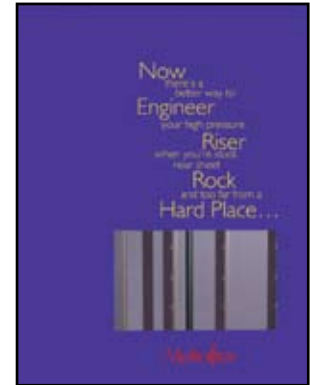

• HI RISE COMPENSATOR

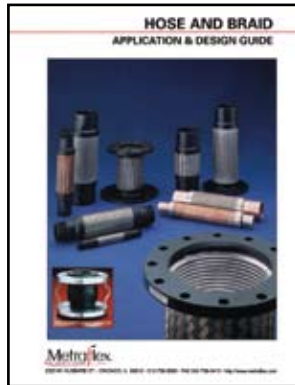

• FLEXIBLE METAL HOSE



• SILENT CHECK VALVES

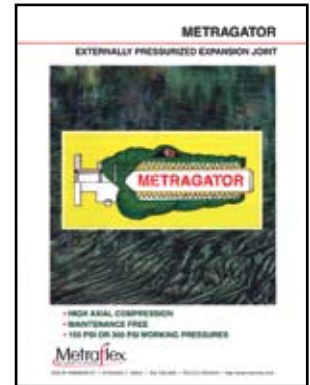

• METRAGATOR EXPANSION JOINTS



• CAST IRON STRAINERS

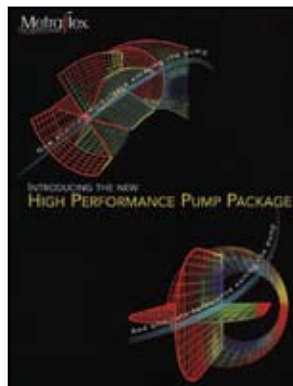

• HIGH PERFORMANCE

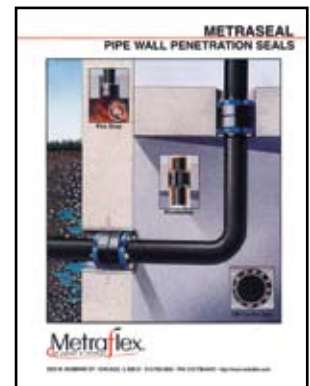

• METRASEAL



Call or write for information on any of these other **METRAFLEX PRODUCTS**

2323 W. HUBBARD ST. • CHICAGO, IL 60612 • 312-738-3800 • FAX 312-738-0415 • <http://www.metraflex.com>

Distributed by: