

**MODEL MPTR  
MULTI-PLY BELLOWS  
PUMP CONNECTOR/  
EXPANSION JOINT**

OPERATING CONDITIONS	
150°F	225 PSI
212°F	190 PSI
480°F	110 PSI

MAXIMUM WORKING  
TEMPERATURE 480 °F

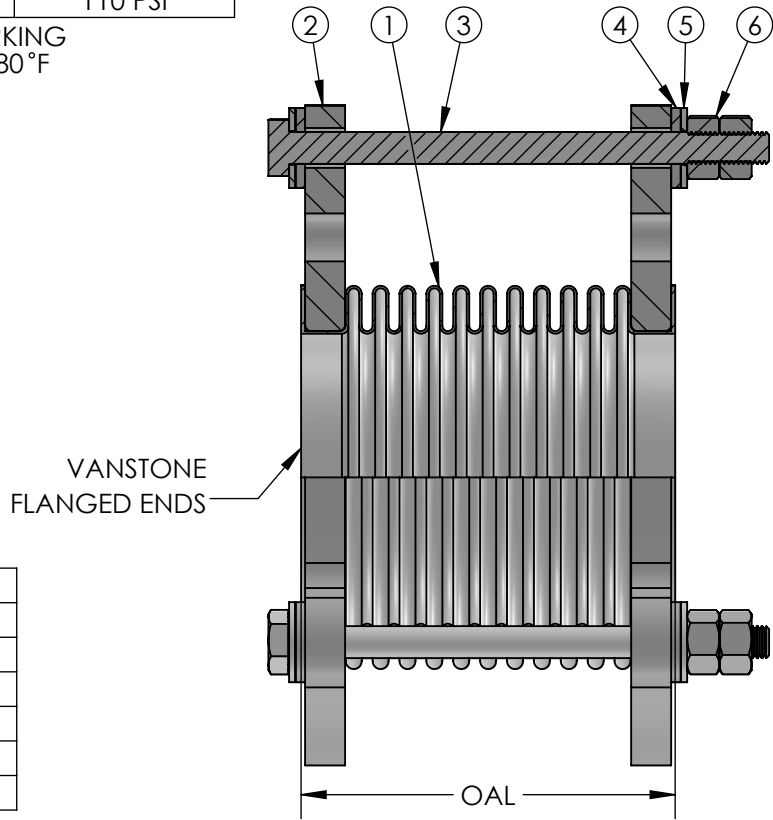
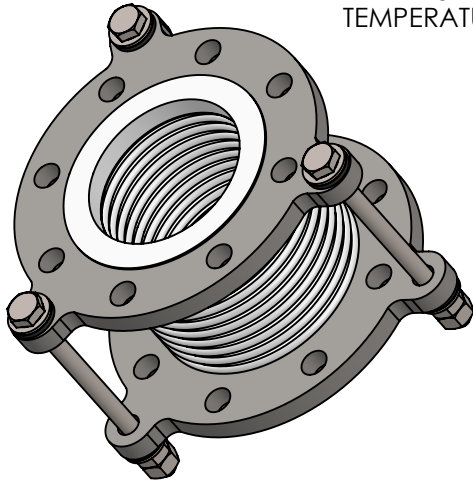

ITEM	PART NAME	MATERIAL
1	BELLOWS (2-PLY)	T304SS
2	ANSI 150# FLANGE	CARBON STEEL
3	TIE RODS	AISI-1020
4	GROMMET	NEOPRENE
5	WASHERS	STEEL
6	NUTS	AISI-1020

ALL WETTED SURFACES STAINLESS STEEL

QTY	PART NUMBER	PIPE SIZE		OAL	MAX COMP.	MAX EXT.	MAX LAT.	NUMBER OF TIE RODS	WEIGHT	PROJECT INFORMATION
		INCH	MM							
	MPTRVS0200	2"	50	6"	0.9"	0.2"	0.66"	3	12	
	MPTRVS0250	2-1/2"	65	6"	0.9"	0.2"	0.53"	3	16	
	MPTRVS0300	3"	80	6"	0.9"	0.2"	0.45"	3	18	
	MPTRVS0400	4"	100	6"	1.0"	0.2"	0.39"	3	28	
	MPTRVS0500	5"	125	6"	1.0"	0.2"	0.31"	3	34	
	MPTRVS0600	6"	150	6"	1.0"	0.2"	0.26"	3	43	
	MPTRVS0800	8"	200	6"	1.0"	0.2"	0.22"	3	63	
	MPTRVS1000	10"	250	8"	1.4"	0.2"	0.33"	3	93	
	MPTRVS1200	12"	300	8"	1.4"	0.2"	0.26"	3	120	
	MPTRVS1400	14"	350	8"	1.4"	0.2"	0.26"	3	160	
	MPTRVS1600	16"	400	8"	0.75"	0.3"	0.13"	3	200	
	MPTRVS1800	18"	450	8"	1"	0.5"	0.13"	3	211	

**NSF 372 - LEAD FREE**

The wetted surface of this product contacted by consumable water contains less than one quarter of one percent (0.25%) of lead by weight. Material complies with state codes and standards, where applicable, requiring reduced lead content.

CUSTOMER: \_\_\_\_\_

PROJECT: \_\_\_\_\_

ENGINEER: \_\_\_\_\_

REV.	DATE
2323 W. HUBBARD ST. CHICAGO, IL 60612 TEL: 312-738-3800 FAX: 312-738-0415 WWW.METRAFLEX.COM	
<b>MODEL MPTR</b> MULTI-PLY BELLOWS EXPANSION JOINT WITH TIE RODS	
DRAWN BY: <b>DKISH</b>	DATE: <b>9/3/2015</b>
APPROVED: <b>ZB</b>	DATE: <b>9/4/2015</b>
SCALE: <b>N/A</b>	DRAWING NUMBER: <b>MPTR</b>